



BMK-27

Dual Remote Filtration System Mounting Kit (DURAMAX) Installation and Servicing Instructions

IMPORTANT NOTICE

Read **all** instructions completely before attempting to install this unit. Improper installation could result in serious system and/or equipment damage. The installation of this system is not difficult, however, some mechanical ability is necessary. If you are not comfortable with the instructions or have questions, **do not attempt the installation.** Consult a mechanic or contact AMSOIL INC. for further instructions or assistance.

WARNING: Extreme care should be taken to avoid bodily harm during installation. Before starting, ensure the engine is cool to avoid burns and **never** work in the engine compartment area with the engine running.

A. Getting started

1. Check all parts against the parts list and inspect for damage.
2. Make sure you have the tools needed for the job.

Recommended tool list

Adjustable wrench	5/16" Allen wrench	Drill
7/16" wrench (2)	Torque Wrench	1/4" drill bit
13/16" wrench	Side Cutter	Center punch
7/8" wrench (2)	Adjustable filter wrench	Hammer
15/16" wrench	Drain oil pan	Vice
1" wrench	1 1/16" wrench	

B. Filter selection

Any one of 8 different size AMSOIL Full-Flow Oil Filters and 3 different AMSOIL By-Pass Filters may be used with this mount. Select a full-flow filter that is equivalent or larger than the one originally installed on your vehicle. The larger the filter used, the greater the filtration capacity and the longer the filter life. The By-Pass filter should be the largest for which space is available. Use the dimension information below as well as the data in diagram A to assist you in selecting your filters.

AMSOIL filters

Full-flow	DIA.	Height	By-Pass	DIA.	Height
EaO-26	3.66"	7.04"	EaBP-110	4.29"	10.44"
EaO-15*	3.66"	5.19"	EaBP-100	4.29"	7.25"
EaO-96	3.66"	4.25"	EaBP-90*	4.29"	5.78"
EaO-42	3.66"	3.92"			
EaO-34	3.02"	4.73"	*Most commonly used filters		
EaO-57	2.92"	3.38"			
EaO-10	2.69"	2.85"			

1. Survey the engine compartment for possible mounting locations. The mount should be located in the same area as the existing full flow filter. Make sure the mounting structure is adequate to carry the weight of the filtration system.
2. The filter mount can be rotated 180° in its mounting brackets. This allows the oil supply and return hoses to enter the mount on either the right or left hand side. Choose the side that will minimize the need for bends in the hoses or the need for additional hose fittings. Also, refer to diagram B for preferred mounting angle positions.
3. When the location has been determined, use the mounting template provided to locate and mark mounting holes. This can be easily done with a center punch and hammer.
4. With a 1/4" drill bit, drill out the previously marked mounting holes and attach the top mount bracket (BP-194). Use the 4 - 1" long 1/4" bolts, nuts, small washer and fender washers provided. Note the assembly diagram D for details. Using two 7/16" wrenches or socket, tighten to 8 foot pounds.
5. Apply thread sealant onto the two "O" ring adapter fittings (BP-289) as noted in diagram E. Install fittings in mount end adjacent to the arrows. Using a 1" wrench tighten to 30 foot pounds. If desired, optional 90° angle fitting (BK-21) or 45° fitting (BK-22) may be installed at this time. See diagram D. **Do not** use thread sealant on either end of the angle fittings, tighten to 525-575 inch pounds or from finger tight rotate an additional 60° or 1/6 of a turn. Keep in mind the direction you wish to have the hoses intersect the mount.

6. Apply thread sealant as noted in diagram E to the Allen head "O" ring plug (BP-191). Using a 5/16" Allen head wrench, install plug in remaining mount port and tighten to 30 foot pounds. **Note:** If optional oil sampling valve is to be used, refer to diagram D and install in place of the Allen head "O" ring plug. Apply thread sealant to the external threads on all components in the BK-13 kit.
7. Attach the filter mount (BK-309) to the mounting brackets using 4-1 1/2" long 1/4" bolts, nuts and washers provided. **Warning:** The bolts **must** be installed so that the nuts are on the side opposite the filter nipples. Failure to do this will result in the bolts hitting the oil filters. Using two 7/16" wrenches or socket, tighten to 8 foot pounds.

C. Oil Supply

1. Using an oil drain pan to capture lost oil, remove the existing engine full-flow filter. Clean the gasket seating area on the engine with a lint free cloth.
2. Temporarily assemble the Filter Adapter Kit by sliding the o-ring (BP-346) on to the adapter nut (BP-405), and then slide the adapter nut into the large center hole of the spin-on adapter. (BP-420) This can be made easier by applying a small amount of oil on the o-ring.
3. Thread the Filter Adapter Kit on to the engine and determine the direction in which you would like the hoses to intersect the adapter. Remove the assembly from the engine.
4. Apply thread sealant, as noted in diagram E one BP-289 and the BP-331 90° fitting. The sealant should be placed on the o-ring side thread only.
5. If you wish to have the hoses intersect the spin-on adapter perpendicular to its top, install the BP-289 straight fitting in the adapter nut and the BP-331 90° fitting on the side of the spin-on adapter, labeled A. Reverse the fitting position if you wish to have the hoses intersect the spin-on adapter parallel to the top of the spin-on adapter.
6. Using a 1" wrench, tighten BP-289 straight fitting to 30 foot-pounds. Thread the BP-331 three full turns and position in desired location. Tighten locking nut on fitting 30 foot-pounds.
7. Apply a thin coating of oil on the spin-on adapter gasket and the adapter nut o-ring.
8. Reassemble adapter and make sure fittings are correctly positioned and tighten adapter nut to 35 – 40 foot-pounds.

D. Oil feed and return lines

Note: The hose and hose fittings supplied with this kit have been matched to provide maximum performance and life expectancy. Interchanging with other types or bands is **not recommended** and **should be avoided.** Should additional hose be required, it may be obtained from AMSOIL, Inc. by ordering part number BP-350 by the foot.

1. (Oil supply hose) Measure the amount of hose (BP-350) you will need to run from the side port on the spin-on adapter (labeled **A**) to the port with arrow pointing **IN** on the filter mount, also labeled **A**. Additional length will be required to accommodate engine movement during operation. Also, consider how the hose will be routed. Make sure the hose does not contact any hot or moving surfaces or sharp edges. Insure a minimum bend radius of 2 1/4" is maintained at all corners. Also, bends in hose should not begin at hose fittings. See diagrams C and H for additional detail. Note: Insure hose has significant additional length to accommodate movement of engine. Note the need for optional 90° fitting.
2. Using a fine tooth hacksaw or utility knife, squarely cut the hose to the proper length.
3. Install hose fittings (BP-360) on both ends of the cut hose. Follow the instructions noted in diagram G. Tools required are one 1" wrench and one 1 1/16" wrench or vise. Note: Do not use any form of thread sealant anywhere on the BP-360 hose fittings.
4. Route the hose assembly as noted in D.1. and connect the hose fittings. Optional 90° fitting (BK-21) or (BK-22) 45° fittings may be installed at this time between the hose fitting and mount or spin-on adapter.
5. Using two 1" wrenches, tighten the hose fitting swivel nuts to 525 – 575 inch-pounds or from finger tight, rotate an additional 60° or 1/6 of a turn. **Note:** Do not use any form of thread sealant anywhere on the hose fittings.
6. (Oil return hose) Repeat steps D.1 through D.5. Connect hose at the center port on the spin-on adapter, labeled **B** and the port with the arrow point **Out**, on the filter mount, labeled **B**.

- Use plastic ties (BP-46) to secure hose in position and away from potential damage. Trim ties with side cutter. **Note:** Over tightening the plastic ties may cause the hose to collapse and restrict oil flow.
- Fill the selected Full-flow and By-pass filters with the same motor oil being used in the vehicle. Lubricate the filter gaskets with oil and spin filters onto mount. Tighten per instructions on the filter can.

E. Start up procedures

- Check that all fittings and hoses are securely attached, and that the hoses are routed properly.
- Check engine oil level. Fill to full mark if necessary.
- With the equipment secured start the engine and immediately check oil pressure. **Note:** Pressure may initially take a moment or two to rise.

Caution: Carefully check for leaks at fittings, hoses and mount. If leaks are observed, **STOP ENGINE IMMEDIATELY**, repair leaks and continue.

- After engine has warmed, shut off and re-check engine oil level. Top off as necessary.
- Record equipment/operating hours and date of installation.

F. Periodic maintenance

- Periodic visual inspection of the fittings and hoses is recommended. Check for leaks, hose deterioration and cuts. Repair and/or replace as necessary.
- Refer to Recommended Filter Change Interval chart for servicing intervals.
- To change the filter elements:
 - Ensure engine is off and use caution as the engine, oil and filter may be hot and could result in an injury.
 - Using a filter wrench, remove the filter elements. Dispose of properly.
 - Clean the filter gasket contact areas on the mount with a clean, lint-free rag.
 - Lubricate the new filter gaskets with clean oil or grease.
 - Fill filters as full as possible with engine oil.
 - Screw on new filters, tighten per instructions on the filter can.
 - Start engine and check for leaks.
 - Check engine oil level, fill as needed.
- Record equipment/operating hours for future reference.

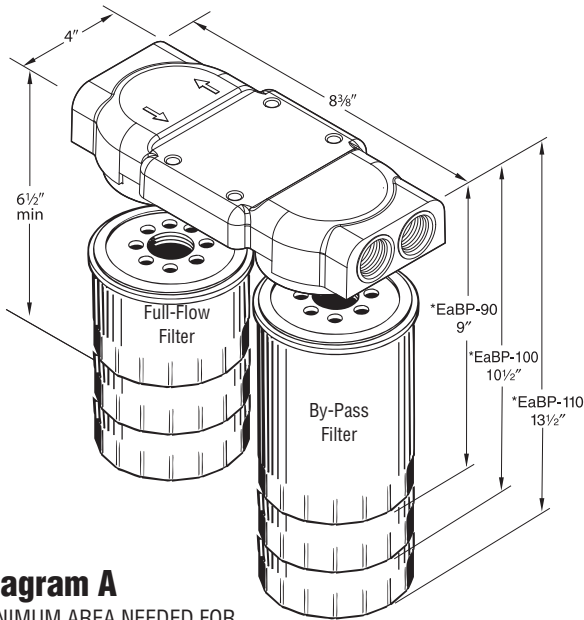

Diagram A

MINIMUM AREA NEEDED FOR DUAL MOUNT AND SPIN-ON OIL FILTER ELEMENTS

* Mount and element heights plus 1-inch removal clearance

Diagram C

Minimum Bend Radius

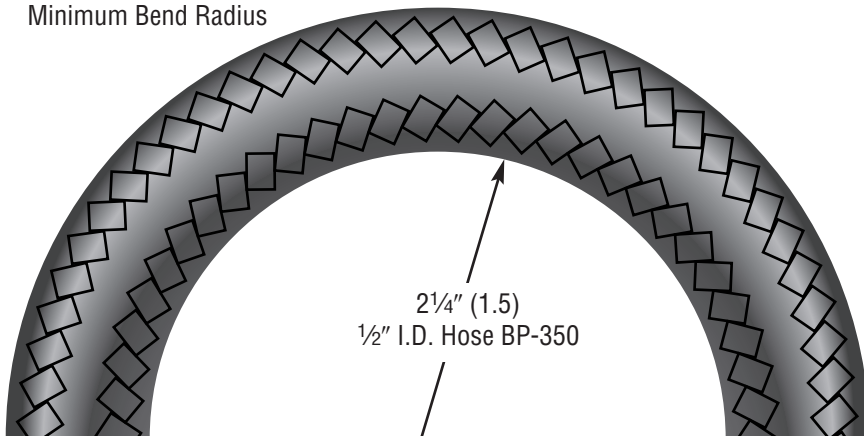

Parts and assembly list

Dual Mount By-pass Filter System (BMK-27) for GM Duramax

Item	Description	Qty.	Part No.
1.	Filter Mount Assembly	1	BK-309
2.	Allen Head Plug	2	BP-191
3.	1/4" 20 x 1" Hex Head Bolt	4	BP-23
4.	1/4" I.D. Washer	6	BP-21
5.	1/4" Self Locking Nuts	8	BP-22
6.	90 degree fitting 7/8"-14 x 5/8" JIC	1	BP-331
7.	"O" ring fitting 7/8"-14 x 5/8" JIC	3	BP-289
8.	Hose Fitting	4	BP-360
9.	1/2" I.D. hose	8'	BP-350
10.	Spin-On Adapter	1	BP-420
11.	Adapter Retaining Nut 1 3/16"-16	1	BP-405
12.	Gasket 3.11" ID	1	BP-220
13.	Mounting Bracket Top	1	BP-194
14.	Mounting Bracket Bottom	1	BP-195
15.	1/4"-20 x 1 1/2" Hex Head Bolt	4	BP-185
16.	1/4" ID Fender Washer	4	BP-186
17.	Adapter Nut O-ring	1	BP-346
	Plastic Tie	2	BP-46
	Thread Sealant	1	BP-198
	Instruction Sheet	1	BP-258
Optional Parts			
	Oil Sampling Kit	1	BK-13
	Deluxe oil sampling valve 1/4" NPT	1	G-1570
	90 degree fitting 7/8"-14 x 5/8" JIC	2	BK-21
	45 degree fitting 7/8"-14 x 5/8" JIC	2	BK-22

Mounting Angle Diagram B

(Recommendations are the same right to left and front to back)
Mounting angle above horizontal is not recommended

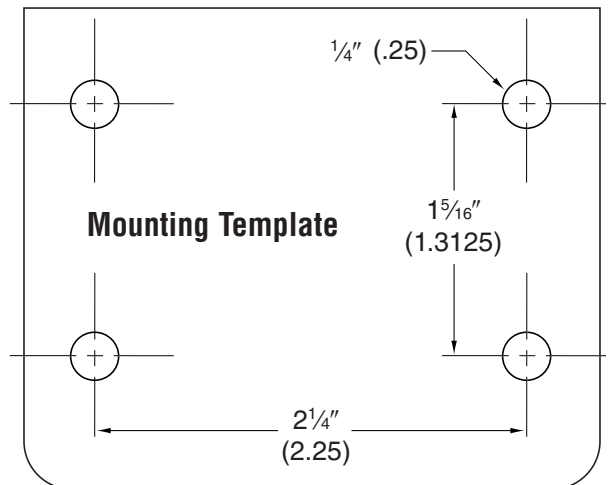
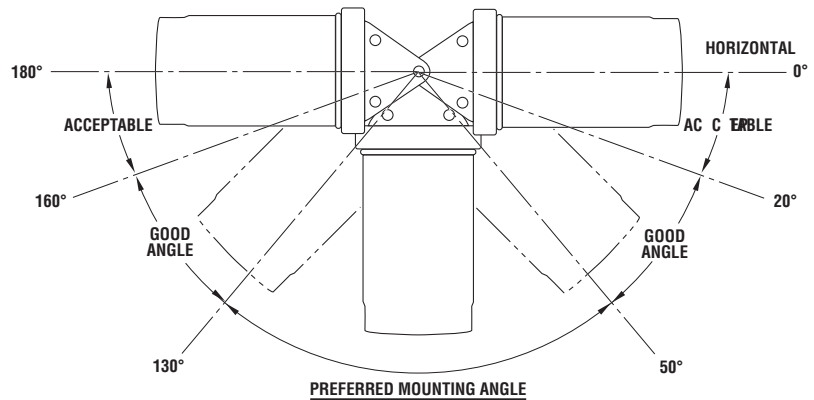

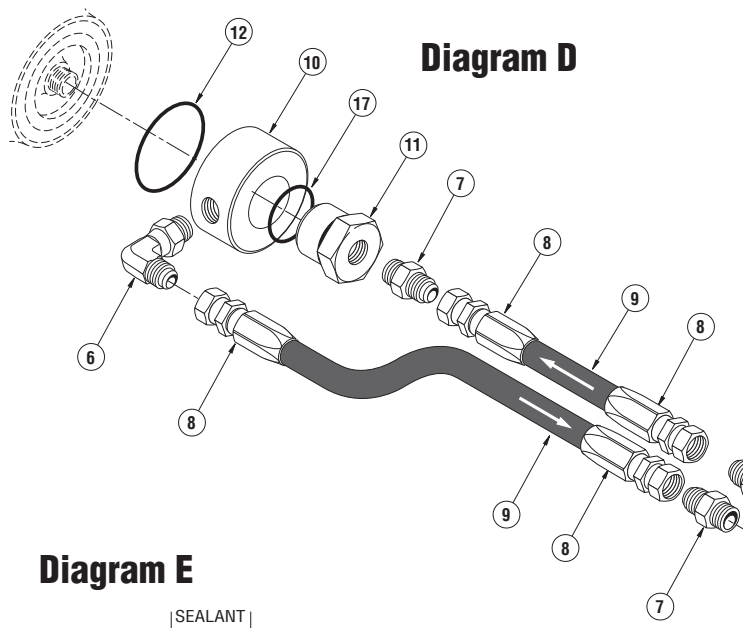
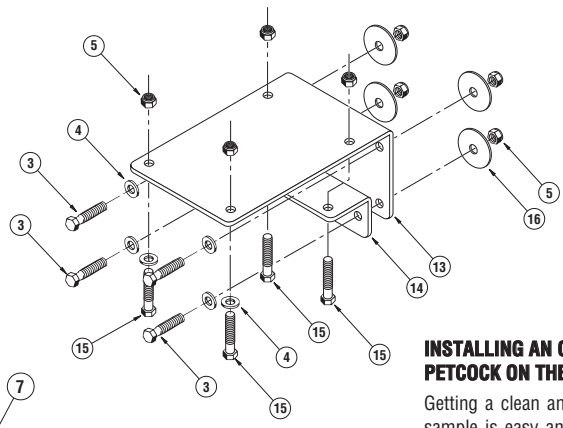

Diagram D



INSTALLING AN OIL SAMPLING PETCOCK ON THE SPIN-ON BY-PASS:

Getting a clean and uncontaminated oil sample is easy and simple when an oil sampling pet-cock is installed into the Spin-On By-Pass Oil Filter system. This can be easily done by ordering a BK-13 Kit.

Diagram E

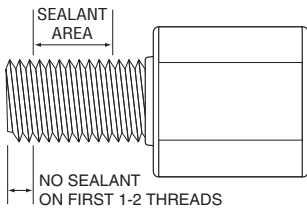

Note: If Teflon tape is used, it should be wrapped no more than 1½ to 2 turns in a clockwise direction when viewed from the thread end.

AMSOIL Full-Flow Filter Sold Separately

AMSOIL By-Pass Filter Sold Separately

Oil Analysis:

For oil analysis vehicles, order G-1318 Oil Analysis Sampling Kits (in U.S., Canada, Puerto Rico), or send samples to the lab of your choice. Consult AMSOIL Technical Service for details.

optional BK-13 Sampling Kit

Diagram F Thread adapters (sold separately)

If your equipment uses this AMSOIL Filter	This is the thread used on that equipment	This is the adapter kit you should use	If your equipment uses this AMSOIL Filter	This is the thread used on that equipment	This is the adapter kit you should use
EaO-10	¾" - 16	BK-295	EaO-44	20mm x 1.5mm	BK-298
EaO-13	20mm x 1.5mm	BK-298	EaO-47	22mm x 1.5mm	BK-299
EaO-15	¾" - 16	BK-295	EaO-52	13/16" - 16	BK-302
EaO-20	20mm x 1.5mm	BK-298	EaO-57	¾" - 16	BK-295
EaO-22	13/16" - 16	BK-296	EaO-64	13/16" - 16	BK-296
EaO-23	18mm x 1.5mm	BK-297	EaO-80	1"-16	BK-300
EaO-24	13/16" - 16	BK-296	EaO-96	¾" - 16	BK-295
EaO-25	13/16" - 16	BK-296	EaO-99	1½"-16	BK-301
EaO-26	¾" - 16	BK-295			
EaO-29	18mm x 1.5mm	BK-297	Adapters		
EaO-30	13/16" - 16	BK-296	¾" - 16		BK-295
EaO-34	¾" - 16	BK-295	13/16" - 16		BK-296
EaO-36	20mm x 1.5mm	BK-298	18mm x 1.5mm		BK-297
EaO-42	¾" - 16	BK-295	20mm x 1.5mm		BK-298
			22mm x 1.5mm		BK-299
			1"-16 (Cummins)		BK-300
			1½"-16 (Power Stroke 7.3 L)		BK-301
			13/16"-16 (Duramax 6.6 L)		BK-302

Diagram G

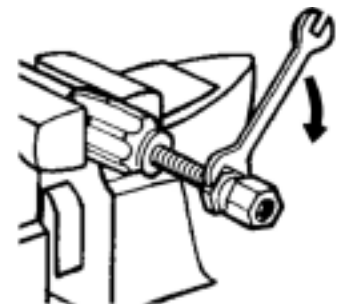
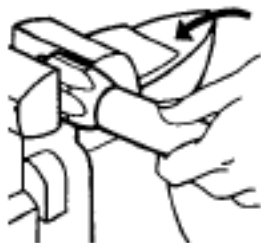

1. Place socket in vice and screw in hose counter-clockwise until hose bottoms. Back hose out ½ turn.

2. Oil inside of hose and the tapered nipple thread areas liberally with oil. Do not oil hose cover. Apply anti-seize to all thread areas.

3. Screw nipple assembly into socket using wrench on nipple hex until nipple hex shoulders against socket.

BMK-27 PARTS IDENTIFICATION SHEET

(4) BP-46
PLASTIC TIE



(4) BP-185
1/4" X 1 1/2"
BOLT

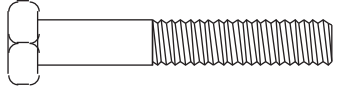

(6) BP-21
1/4" I.D. WASHER

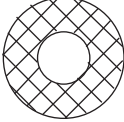

(4) BP-186
1/4" FENDER
WASHER

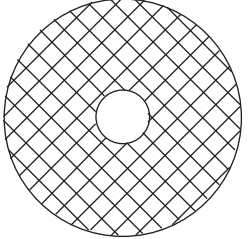

(8) BP-22
1/4" NUT



(4) BP-23
1/4" X 1" BOLT

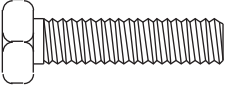

(4) BP-360
HOSE FITTING

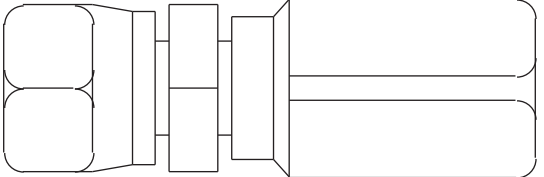

(1) BP-420
FILTER ADAPTER
NOT TO SCALE

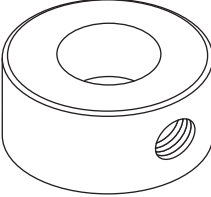

(8) BP-350
1/2" I.D. HOSE



(2) BP-191
ALLEN HEAD
PLUG



(3) BP-289
"O" RING
FITTING
ADAPTER

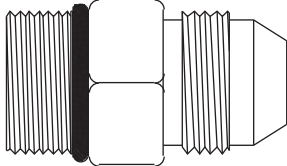

(1) BP-194
MOUNTING
BRACKET
TOP
NOT TO SCALE

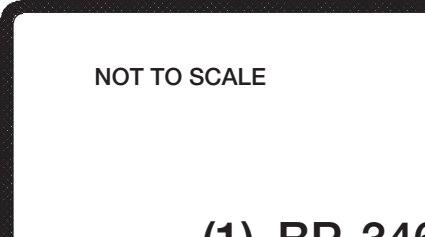

(1) BP-331
90° Fitting



(1) BP-195
MOUNTING
BRACKET
BOTTOM
NOT TO SCALE



(1) BP-346
Adapter Nut "O" Ring



(1) BP-405 13/16" - 16 Thread
Adapter retaining nut

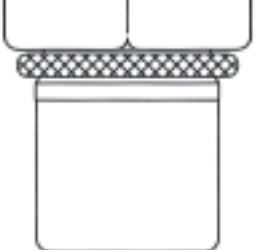

(1) BP-220
"O" RING
3.11" I.D.



(1) BK-309
FILTER MOUNT
ASSEMBLY

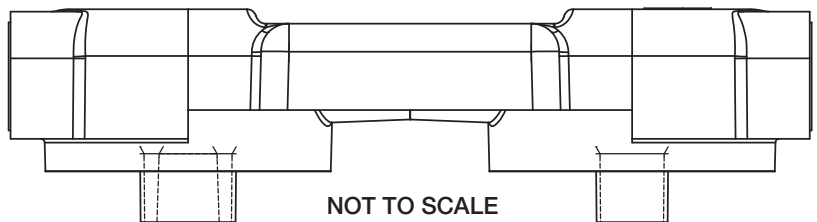
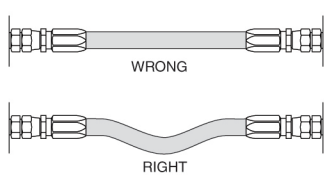
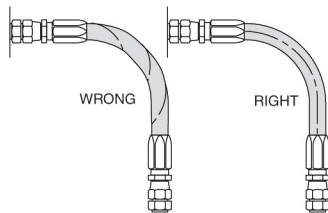

Diagram H Hose routing examples



1. Provide for length change

In straight hose installations allow enough slack in the hose line to provide for changes in length that will occur when pressure is applied. This change in length can be from +2% to -4%.



2. Avoid twisting and orient properly

Do not twist hose during installation. This can be determined by the printed layline on the hose. Pressure applied to a twisted hose can cause hose failure or loosening of connections.

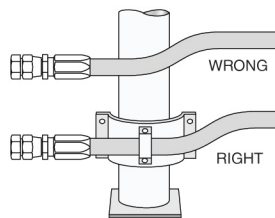

3. Protect from hazardous environment

Keep hose away from hot parts. High ambient temperature will shorten hose life. If you can not route it away from the heat source, insulate it.

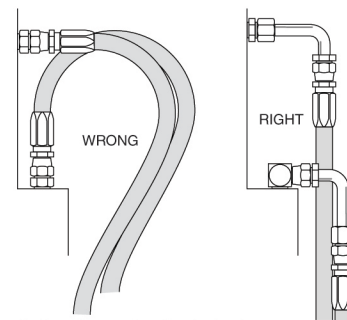

4. Avoid mechanical strain

Use elbows and adapters in the installation to relieve strain on the assembly, and to provide easier and neater installations that are accessible for inspection and maintenance.

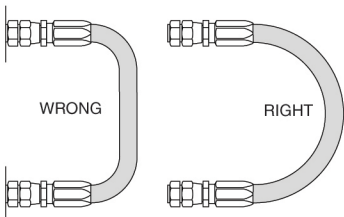

5. Use proper bend radius

Keep the bend radius of the hose as large as possible to avoid collapsing of the hose and restriction of flow. Follow catalog specs on minimum bend radii.

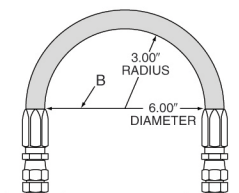

6. Use proper bend radius (cont.)

Maximum bend radius is measured on the inside bend of the hose. To determine minimum bend, divide the total distance between ends (B length) by 2. For example $8 \div 2 = 4$, minimum bend radius = 4.

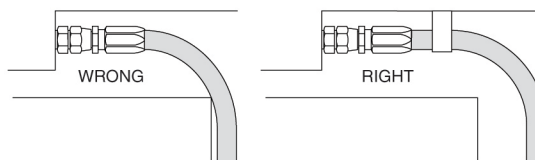

7. Secure for protection

Install hose runs to avoid rubbing or abrasion. Use clamps to support long runs of hose or to keep hose away from moving parts. It is important that the clamps do not allow the hose to move. This movement will cause abrasion and premature hose failure.

8. Avoid Improper Hose Movement

Make sure relative motion of the machine components produces bending rather than twisting of the hose. Hose should be routed so that the flex is in the same plane as the equipment movement.

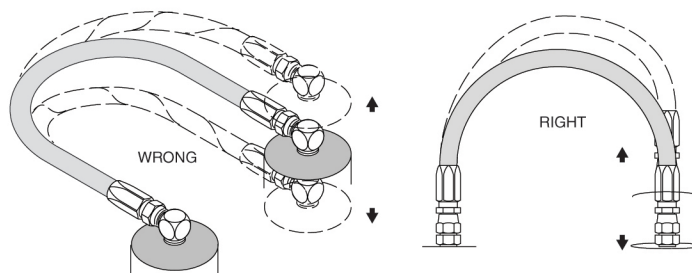

AMSOIL Oil Filter Change Recommendations

Vehicles with Gasoline or Diesel Fueled Engines

- **EaO and Donaldson Endurance ELF 7349** (Dodge Cummins 5.9L): Up to 25,000 miles (15,000 miles for severe service) or one-year service life, whichever comes first, when used in conjunction with AMSOIL Synthetic oil. Always change oil filter at time of oil change.
- **EaBP By-pass Filters:** Should be changed every other full flow filter change up to 60,000 miles, whichever comes first. When used with other brands of motor oil or full flow filters, the EaBP should be changed every other full flow filter change. AMSOIL recommends using oil analysis when extending oil drain intervals.
- **Donaldson Endurance:** Heavy-duty commercial vehicles and off road equipment, when used in conjunction with AMSOIL Synthetic oil, up to two times longer than OEM* recommendations, not to exceed 60,000 miles for on-highway diesel applications. Always change oil filter at the time of oil change.
- **WIX and Donaldson®P™ Series:** OEM* Recommendations.

Stationary Engines

- **EaO and Donaldson Endurance:** Up to two times longer than OEM* recommendations. Always change oil filter at time of oil change.
- **WIX and Donaldson®P™ Series:** OEM* Recommendations.

To order By-Pass Oil Filter Parts or oil sample kits, consult your AMSOIL Dealer or the AMSOIL Product Price List for your country.

Jeff Fisher

www.synthetisoils.us

AMSOIL INC., AMSOIL Bldg., Superior, WI (715) 392-7101

(512) 241-9280

(866) 292-4700

BP-258 1/08

Diagram H Hose routing examples

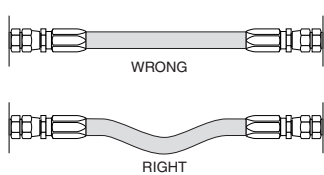

1. Provide for length change

In straight hose installations allow enough slack in the hose line to provide for changes in length that will occur when pressure is applied. This change in length can be from +2% to -4%.

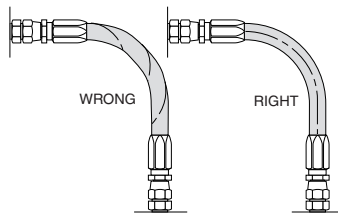

2. Avoid twisting and orient properly

Do not twist hose during installation. This can be determined by the printed layline on the hose. Pressure applied to a twisted hose can cause hose failure or loosening of connections.

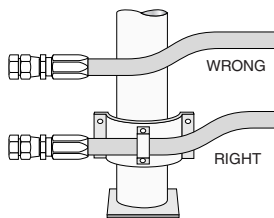

3. Protect from hazardous environment

Keep hose away from hot parts. High ambient temperature will shorten hose life. If you can not route it away from the heat source, insulate it.

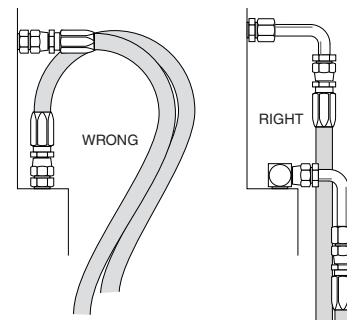

4. Avoid mechanical strain

Use elbows and adapters in the installation to relieve strain on the assembly, and to provide easier and neater installations that are accessible for inspection and maintenance.

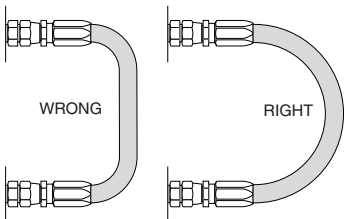

5. Use proper bend radius

Keep the bend radius of the hose as large as possible to avoid collapsing of the hose and restriction of flow. Follow catalog specs on minimum bend radii.

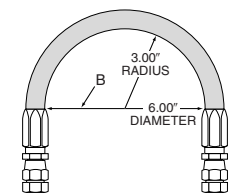

6. Use proper bend radius (cont.)

Maximum bend radius is measured on the inside bend of the hose. To determine minimum bend, divide the total distance between ends (B length) by 2. For example $8 \div 2 = 4$, minimum bend radius = 4.

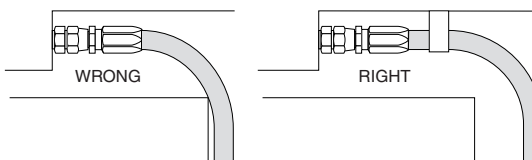

7. Secure for protection

Install hose runs to avoid rubbing or abrasion. Use clamps to support long runs of hose or to keep hose away from moving parts. It is important that the clamps do not allow the hose to move. This movement will cause abrasion and premature hose failure.

8. Avoid Improper Hose Movement

Make sure relative motion of the machine components produces bending rather than twisting of the hose. Hose should be routed so that the flex is in the same plane as the equipment movement.

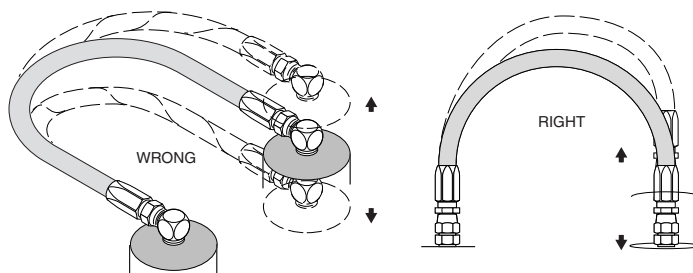

AMSOIL Oil Filter Change Recommendations

Vehicles with Gasoline or Diesel Fueled Engines

- **EaO and Donaldson Endurance ELF 7349** (Dodge Cummins 5.9L): Up to 25,000 miles (15,000 miles for severe service) or one-year service life, whichever comes first, when used in conjunction with AMSOIL Synthetic oil. Always change oil filter at time of oil change.
- **EaBP By-pass Filters:** Should be changed every other full flow filter change up to 60,000 miles, whichever comes first. When used with other brands of motor oil or full flow filters, the EaBP should be changed every other full flow filter change. AMSOIL recommends using oil analysis when extending oil drain intervals.
- **Donaldson Endurance:** Heavy-duty commercial vehicles and off road equipment, when used in conjunction with AMSOIL Synthetic oil, up to two times longer than OEM* recommendations, not to exceed 60,000 miles for on-highway diesel applications. Always change oil filter at the time of oil change.
- **WIX and Donaldson™P™ Series:** OEM* Recommendations.

Stationary Engines

- **EaO and Donaldson Endurance:** Up to two times longer than OEM* recommendations. Always change oil filter at time of oil change.
- **WIX and Donaldson™P™ Series:** OEM* Recommendations.

To order By-Pass Oil Filter Parts or oil sample kits, consult your AMSOIL Dealer or the AMSOIL Product Price List for your country.