



BMK-14

Remote Filtration System Mounting Kit Installation and Servicing Instructions

IMPORTANT NOTICE

Read **all** instructions completely before attempting to install this unit. Improper installation could result in serious system and/or equipment damage. The installation of this system is not difficult, however, some mechanical ability is necessary. If you are not comfortable with the instructions or have questions, **do not attempt the installation.** Consult a mechanic or contact AMSOIL INC. for further instructions or assistance.

WARNING: Extreme care should be taken to avoid bodily harm during installation. Before starting, ensure the engine is cool to avoid burns and **never** work in the engine compartment area with the engine running.

A. Getting started

1. Check all parts against the parts list and inspect for damage.
2. Make sure you have the tools needed for the job.

Recommended tool list

Adjustable wrench	Torque Wrench	Drill
1/2" wrench (2)	Side Cutter	5/16" drill bit
13/16" wrench	Utility knife	Center punch
7/8" wrench (2)	Adjustable filter wrench	Hammer
15/16" wrench	Drain oil pan	Vice

B. Filter selection

Any one of 8 different size AMSOIL Full-Flow Oil Filters may be used with this mount. Select one that is equivalent or larger in size than the one originally installed on your vehicle. The larger the filter used, the greater the filtration capacity and the longer the filter life. Space available under the hood is a key consideration. Use the dimension information below as well as the data in diagram A to assist you in selecting a filter.

AMSOIL Full-flow filters	DIA.	Height
EaO-26	3.66"	6.85"
EaO-15	3.66"	5.35"
EaO-96	3.66"	4.21"
EaO-42	3.66"	3.95"
EaO-34	3.02"	4.72"
EaO-57	2.92"	3.40"
EaO-10	2.69"	3.40"

C. Attaching the filter mount

1. Survey the engine compartment for possible mounting locations. The mount should be located as close to the existing full-flow filter as possible. Solid structures such as the firewall, fender well, or radiator support or frame are common locations. **(Do not mount on engine)** Refer to diagram A for minimum area requirements and consider accessibility for servicing.
2. Refer to diagram B for preferred mounting angle positions.
3. When the location has been determined, use the mounting template provided to locate and mark mounting holes. This can be easily done with a center punch and hammer.
4. Install two "O" ring adapter fittings (BP-189) on filter mount (BK-204) using provided thread sealant as noted in diagram E. If desired, optional 90° angle fittings (BK-11) or 45° angle fittings (BK-12) may also be used. Sold in packages of two, they are available from AMSOIL INC. Using a 7/8" wrench, tighten to 40-43 foot pounds. **Do not** use thread sealant on either end of the angle fittings, tighten to 525-575 inch pounds or from finger tight, rotate an additional 60° or 1/6 of a turn. Keep in mind the direction you wish to have the hoses intersect the mount.
5. With a 5/16" drill bit, drill out the previously marked mounting holes and attach the mount using the 5/16" bolts, nuts, small washer and fender washers provided. Bolts should be tightened to 16-18 foot pounds. 1/2" wrenches and/or sockets will be required for this operation.

D. Oil Supply

1. Using a 13/16" wrench, install two adapter fittings (BP-190) into the Spin-On filter adapter (BP-159) using thread sealant as noted in diagram E. Tighten to 28 foot pounds or 2-3 turns beyond finger tight.
2. Using an oil drain pan to control any loss of oil, remove the existing engine full-flow oil filter. Clean the gasket seating area on the engine with a clean lint free cloth.
3. With the engine filter nipple now exposed, match it with one of the four color-coded adapter bushings (BP-163 through 166). The correct bushing will thread on the nipple easily and with little free play. If you were previously using an AMSOIL Full-Flow Oil Filter or know the nipple thread size, use diagram F to determine the proper Adapter bushing color.
4. Apply thread sealant to the outside thread of the selected bushing. Note diagram E.
5. With the knurled end of the bushing pointing out, thread into the spin-on filter adapter (BP-159).
6. Two "O" rings sizes and an adapter plate (BP-160) are provided to accommodate a variety of filter gasket seating areas. Compare the "O" rings with the seating area on the engine. If the larger "O" ring is to be used, so must the adapter plate and small "O" ring. **Note:** The large "O" ring and adapter plate are normally only required in applications in which the engine calls for an AMSOIL EaO-24 or EaO-25 or equivalent full-flow oil filter.
7. To ensure proper sealing and aid in installation, place a small amount of grease on both sides of the "O" ring(s) used. Install the spin-on filter adapter in place of the old oil filter. Tighten the adapter one full turn after adapter first contacts sealing surface, back off slightly, about 1/8"

E. Oil feed and return lines

Note: The hose and hose fittings supplied with this kit have been matched to provide maximum performance and life expectancy. Interchanging with other types or brands is **not recommended** and **should be avoided.** Should additional hose be required, it may be obtained from your AMSOIL Dealer by ordering part number BP-250.

1. (Oil supply hose) Measure the amount of hose (BP-250) you will need to run from the **Red** colored port (labeled **Out**) on the spin-on adapter to the port labeled **In** on the filter mount. Additional length will be required to accommodate engine movement during operation. Also consider how the hose will be routed. Make sure the hose does not contact any hot or moving surfaces or sharp edges. Ensure a minimum bend radius of 1 1/2" is maintained at all corners. Also, bends in hose should not begin at hose fittings. See diagrams C and H for additional details.
2. Using a utility knife, squarely cut the hose to the proper length.
3. Install hose fittings (BP-260) on both ends of the hose. Follow the instructions noted in diagram G. Tools required are one 7/8" wrench and one 15/16" wrench or vise. **Note:** Do not use any form of thread sealant anywhere on the BP-260 hose fittings.
4. Route the hose assembly as noted in E.1 and connect the hose fittings. **Note:** Optional 90° or 45° angle fittings may be installed at this time between the hose fittings and spin-on-adapter.
5. Using two 7/8" wrenches, tighten hose fitting swivel nuts and swivel nuts on angle fittings (if used) to 525-575 inch pounds or from finger tight, rotate an additional 60° or 1/6 of a turn. **Note:** Do not use any form of thread sealant anywhere on the hose or angle fittings.
6. (Oil return hose) Repeat steps E.1 through E.5. Connect hose at port labeled **In** on the spin-on adapter and port labeled **Out** on the filter mount.
7. Use plastic ties (BP-46) to secure hose in position and away from damage. Trim ties, using a side cutter. **Note:** Over tightening the plastic ties may cause the hose to collapse and restrict oil flow.
8. Fill the new Full-Flow Filter with the same motor oil being used in the vehicle. Lubricate the filter gasket with oil and spin filter onto mount. Tighten per instructions on the filter.

F. Start up procedures

1. Check that all fittings and hoses are securely attached, and that the hoses are routed properly.
2. Check engine oil level. Fill to full mark if necessary.

3. Set vehicle parking brake. With transmission in park/neutral start the engine and immediately check oil pressure. **Note:** Pressure may initially take a moment or two to rise.

Caution: Carefully check for leaks at fittings, hoses and mount. If leaks are observed, **STOP ENGINE IMMEDIATELY**, repair leaks and continue.

4. After engine has warmed, shut off and re-check engine oil level. Fill as necessary.
5. Record vehicle mileage/operating hours and date of installation.

G. Periodic maintenance

1. Periodic visual inspection of the fittings and hoses is recommended. Look for leaks, hose deterioration and cuts. Repair and/or replace as necessary.
2. Refer to Recommended Filter Change Interval chart for servicing intervals.
3. To change the filter element:
 - a. Ensure engine is off and use caution as the engine, oil and filter may be hot and could result in an injury.
 - b. Using a filter wrench, remove the filter element. Dispose of properly.
 - c. Clean the filter gasket contact area on the mount with a clean, lint-free rag.
 - d. Lubricate the new filter gasket with clean oil or grease.
 - e. Fill filters as full as possible with engine oil.
 - f. Screw on new filter, tighten per instructions on filter can.
 - g. Start engine and check for leaks.
 - h. Check engine oil level, fill as needed.
4. Record vehicle mileage/operating hours for future reference.

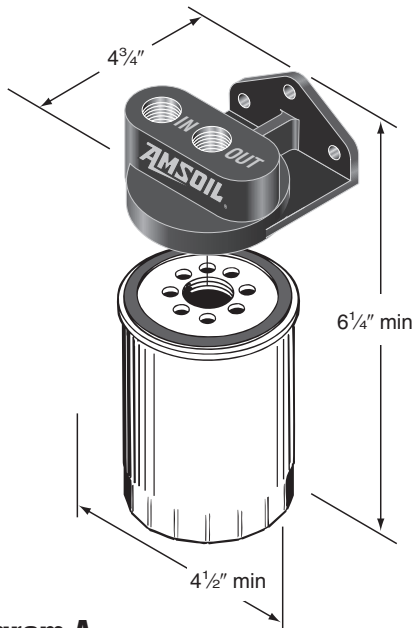
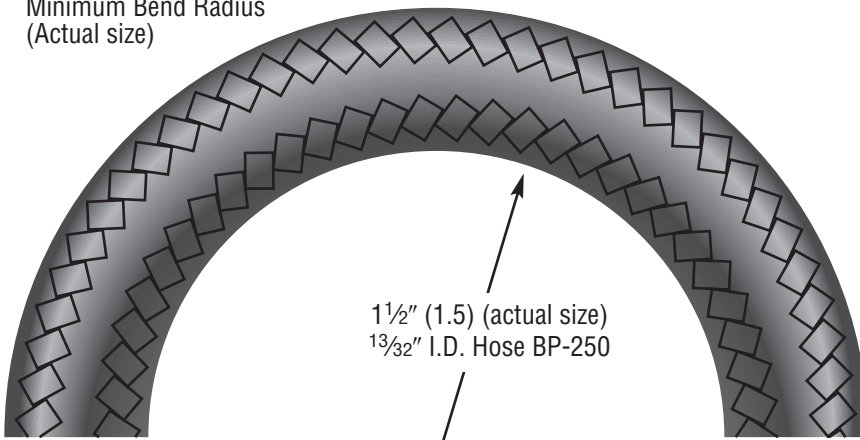

Diagram A

MINIMUM AREA NEEDED FOR REMOTE MOUNT FITTINGS, AND SMALLEST SPIN-ON OIL FILTER ELEMENT.

Diagram C

Minimum Bend Radius
(Actual size)



Parts and assembly list

Item	Description	Qty.	Part No.
1.	Filter Mount Assembly, Spin-On	1	BK-204
2.	"O" Ring Fitting Adapter 3/4"-16 x 1/2" J.I.C.	2	BP-189
3.	Adapter Fitting 3/8" N.P.T. x 1/2" J.I.C.	2	BP-190
4.	5/16" Fender Washer	3	BP-205
5.	5/16" Flat Washer	3	BP-120
6.	5/16"-18 Self Locking Nut	3	BP-121
7.	5/16"-18 x 1" Hex Head Bolt	3	BP-122
8.	1 3/32" I.D. Hose	8'	BP-250
9.	Hose Fitting	4	BP-260
10.	Spin-On Filter Adapter	1	BP-159
11.	"O" Ring Small	1	BP-196
12.	"O" Ring Casting	1	BP-160
13.	"O" Ring Large	1	BP-162
14A.	Thread Adapter 3/4"-16 (white)	1	BP-163
14B.	Thread Adapter 13/16"-16 and 20 mm-1.5 mm (blue)	1	BP-164
14C.	Thread Adapter 18mm-1.5 mm (red)	1	BP-165
14D.	Thread Adapter 22mm-1.5 mm (yellow)	1	BP-166
	Plastic Tie	2	BP-46
	Thread Sealant	1	BP-198
	Instruction Sheet	1	BP-173
Optional Parts Available From AMSOIL INC.			
	90° Fitting, Pack of 2		BK-11
	45° Fitting, Pack of 2		BK-12

Mounting Angle Diagram B

(Recommendations are the same right to left and front to back)
Mounting angle above horizontal is not recommended

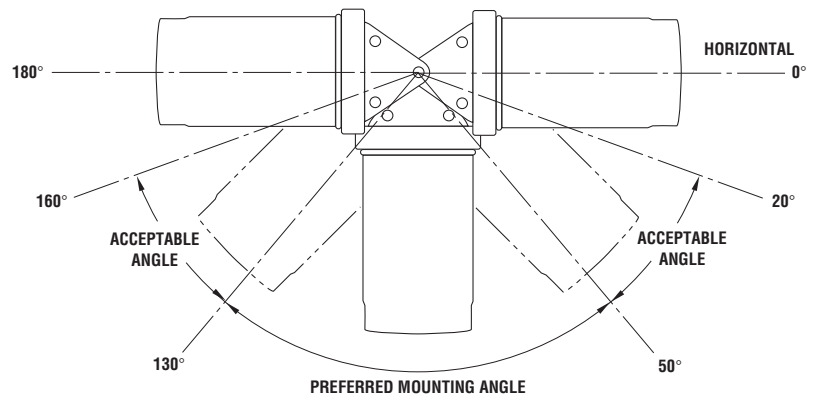

Mounting Template

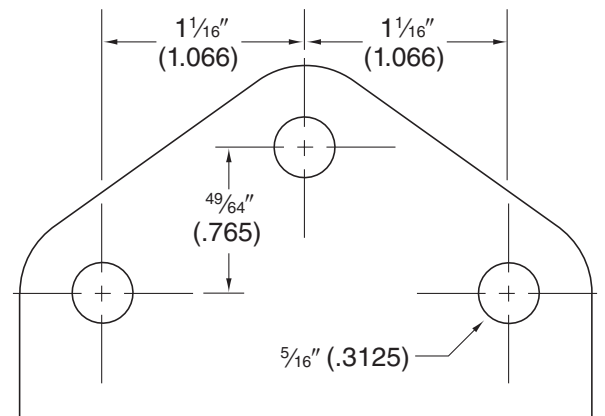

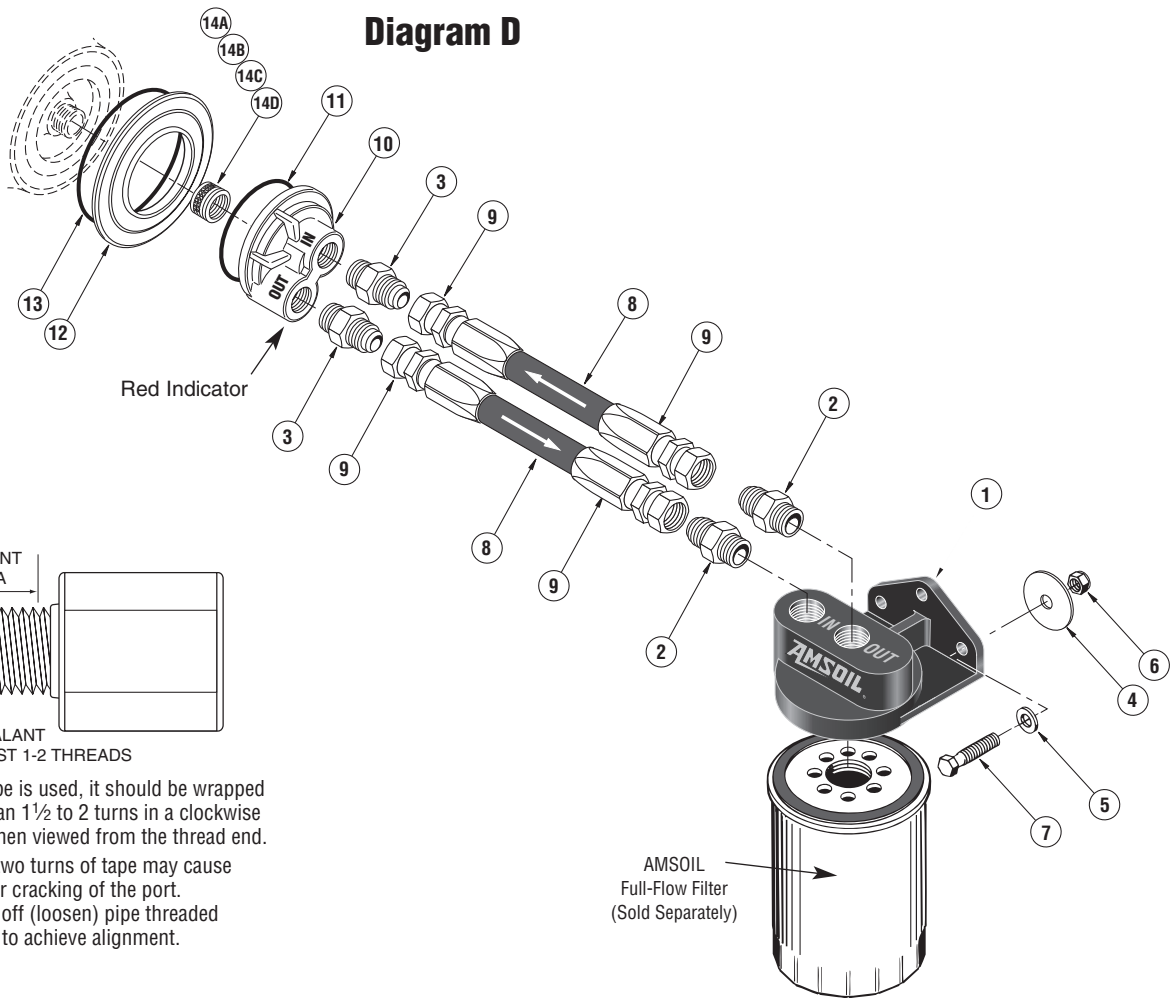
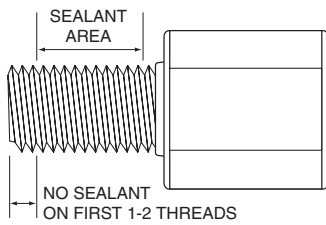

Diagram E



Note: If Teflon tape is used, it should be wrapped no more than 1½ to 2 turns in a clockwise direction when viewed from the thread end.

Caution: More than two turns of tape may cause distortion or cracking of the port. Never back off (loosen) pipe threaded connectors to achieve alignment.

Diagram F Thread adapters

If your vehicle uses this AMSOIL Filter	This is the thread used on that vehicle	This is the bushing color you should use	If your vehicle uses this AMSOIL Filter	This is the thread used on that vehicle	This is the bushing color you should use
EaO-10	¾" - 16	White	EaO-44	20mm x 1.5mm	Blue
EaO-11	22mm x 1.5mm	Yellow	EaO-57	¾" - 16	White
EaO-13	20mm x 1.5mm	Blue	EaO-64	1³⁄₁₆" - 16	Blue
EaO-15	¾" - 16	White	EaO-96	¾" - 16	White
EaO-20	20mm x 1.5mm	Blue	EaO-99	1½" - 16	Use BMK-16
EaO-22	1³⁄₁₆" - 16	Blue	Adapters		
EaO-23	18mm x 1.5mm	Red	White	¾" - 16	
EaO-24	1³⁄₁₆" - 16	Blue	Red	18mm x 1.5mm	
EaO-25	1³⁄₁₆" - 16	Blue	Yellow	22mm x 1.5mm	
EaO-26	¾" - 16	White	Blue	20mm x 1.5mm and 1³⁄₁₆" - 16	
EaO-29	18mm x 1.5mm	Red			
EaO-30	1³⁄₁₆" - 16	Blue			
EaO-34	¾" - 16	White			
EaO-36	20mm x 1.5mm	Blue			
EaO-41	¾" - 16	White			
EaO-42	¾" - 16	White			

Diagram G

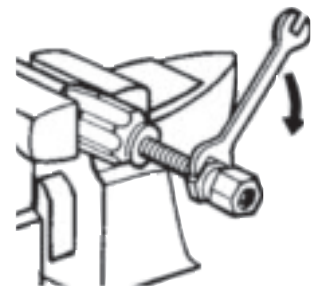
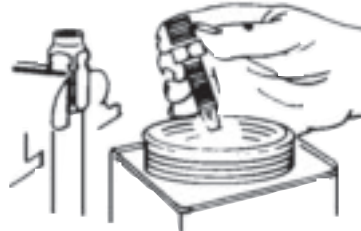

1. Place socket in vice and screw in hose counter-clockwise until hose bottoms. Back hose out ½ turn.

2. Oil inside of hose and nipple threads liberally with oil. Do not oil hose cover.

3. Screw nipple assembly into socket using wrench on nipple hex until nipple hex shoulders against socket.

BMK-14 PAGE TWO

(1) BP-196



SMALL "O" RING
2½" I.D.

(1) BK-204

FILTER MOUNT

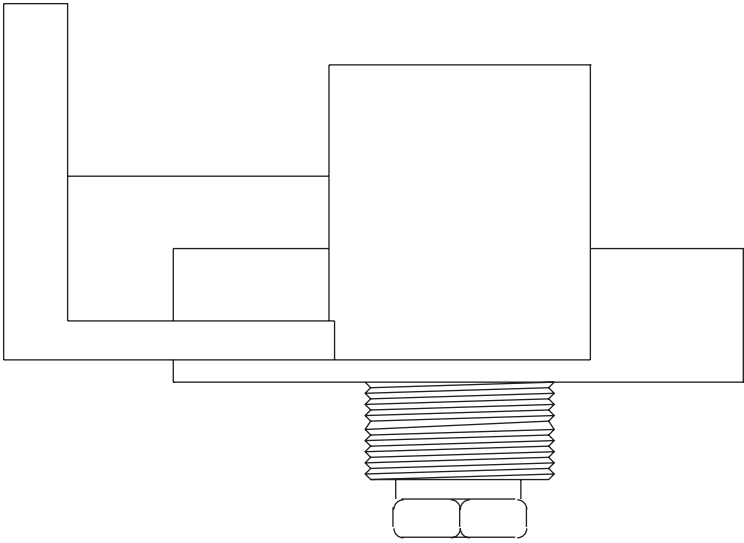

(3) BP-205

5/16" FENDER
WASHER

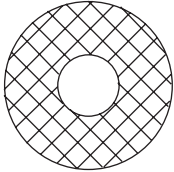

BMK-14 PARTS IDENTIFICATION SHEET

(2) BP-46 
 PLASTIC TIE

(1) BP-165 
 ADAPTER RED
 18 mm - 1.5 mm

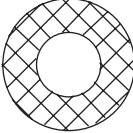
(3) BP-120 
 5/16" WASHER

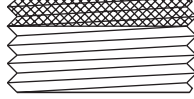
(1) BP-166 
 ADAPTER YELLOW
 22 mm - 1.5 mm

(3) BP-121 
 5/16" NUT

(3) BP-122 
 5/16" x 1" BOLT

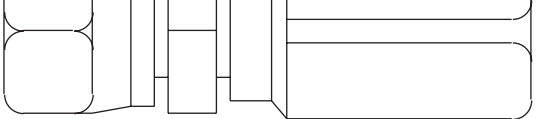
(4) BP-260 
 HOSE FITTING

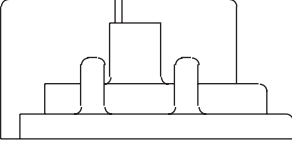
(1) BP-159 
 FILTER ADAPTER
 NOT TO SCALE

(8) BP-250 
 13/32" HOSE

(1) BP-160 
 "O" RING CASTING
 NOT TO SCALE

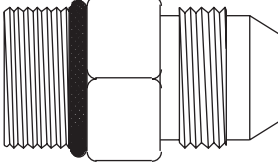
(2) BP-189 
 "O" RING
 FITTING
 ADAPTER

(1) BP-162 
 LARGE "O" RING
 3 3/8" I.D.
 NOT TO SCALE

(1) BP-163 
 ADAPTER WHITE
 3/4" - 16

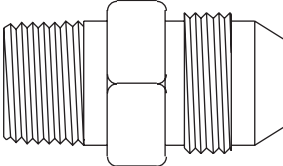
(2) BP-190 
 ADAPTER
 FITTING

(1) BP-164 
 ADAPTER BLUE
 13/16" - 16
 20 mm - 1.5 mm

Diagram H Hose routing examples

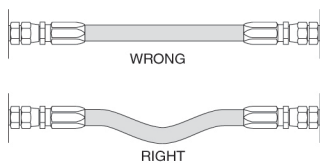

1. Provide for length change

In straight hose installations allow enough slack in the hose line to provide for changes in length that will occur when pressure is applied. This change in length can be from +2% to -4%.

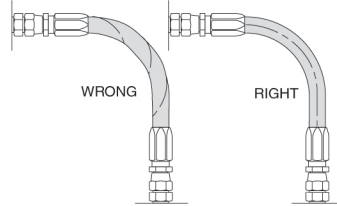

2. Avoid twisting and orient properly

Do not twist hose during installation. This can be determined by the printed layline on the hose. Pressure applied to a twisted hose can cause hose failure or loosening of connections.

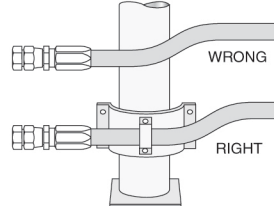

3. Protect from hazardous environment

Keep hose away from hot parts. High ambient temperature will shorten hose life. If you can not route it away from the heat source, insulate it.

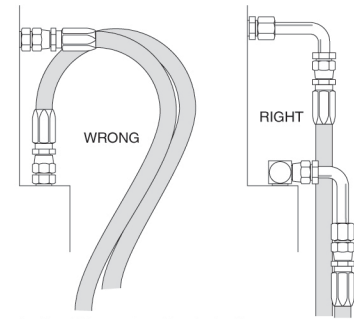

4. Avoid mechanical strain

Use elbows and adapters in the installation to relieve strain on the assembly, and to provide easier and neater installations that are accessible for inspection and maintenance.

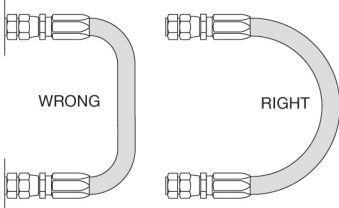

5. Use proper bend radius

Keep the bend radius of the hose as large as possible to avoid collapsing of the hose and restriction of flow. Follow catalog specs on minimum bend radii.

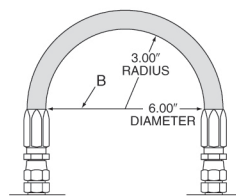

6. Use proper bend radius (cont.)

Maximum bend radius is measured on the inside bend of the hose. To determine minimum bend, divide the total distance between ends (B length) by 2. For example B = 6, minimum bend radius = 3.

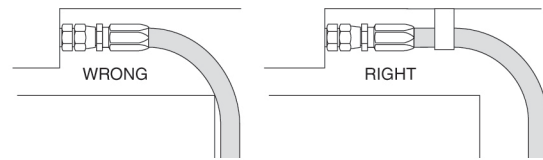

7. Secure for protection

Install hose runs to avoid rubbing or abrasion. Use clamps to support long runs of hose or to keep hose away from moving parts. It is important that the clamps do not allow the hose to move. This movement will cause abrasion and premature hose failure.

8. Avoid Improper Hose Movement

Make sure relative motion of the machine components produces bending rather than twisting of the hose. Hose should be routed so that the flex is in the same plane as the equipment movement.

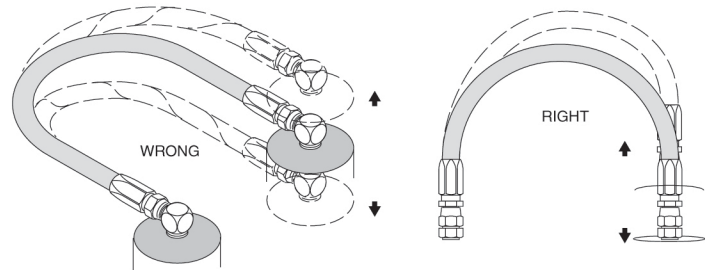

AMSOIL Filter Change Recommendations Lube Filters

Vehicles with Gasoline or Diesel Fueled Engines

- **EaO and Donaldson Endurance ELF 7349** (Dodge Cummins 5.9L): Change filter at time of oil change up to 25,000 miles or one-year service life, whichever comes first, when used in conjunction with AMSOIL Synthetic Motor Oil.
- **Donald Endurance:** Heavy-duty commercial vehicles and off-road equipment, when used in conjunction with AMSOIL Synthetic Motor Oil, change filter up to two times longer than OEM* recommendations, not to exceed 60,000 miles for on-highway diesel applications. Always change oil filter at the time of oil change.
- **WIX and Donaldson P Series:** OEM recommendations.

Stationary Engines

- **EaO and Donaldson Endurance:** up to two times longer than OEM* recommendations. Always change oil filter at time of oil change.
- **WIX and Donaldson P Series:** OEM* recommendations.

*Original Equipment Manufacturer

To order By-Pass Oil Filter Parts or oil sample kits, consult your AMSOIL Dealer or the AMSOIL Product Price List for your country. Most of these items are available from your AMSOIL Product Center.