



BMK-13

U.S. Patent #5,298,158

Dual Remote Filtration System Mounting Kit Installation and Servicing Instructions

IMPORTANT NOTICE

Read **all** instructions completely before attempting to install this unit. Improper installation could result in serious system and/or equipment damage. The installation of this system is not difficult, however, some mechanical ability is necessary. If you are not comfortable with the instructions or have questions, **do not attempt the installation.** Consult a mechanic or contact AMSOIL INC. for further instructions or assistance.

WARNING: Extreme care should be taken to avoid bodily harm during installation. Before starting, ensure the engine is cool to avoid burns and **never** work in the engine compartment area with the engine running.

A. Getting started

1. Check all parts against the parts list and inspect for damage.
2. Make sure you have the tools needed for the job.

Recommended tool list

Adjustable wrench	Torque Wrench	Drill
7/16" wrench (2)	Side Cutter	1/4" drill bit
13/16" wrench	Utility knife	Center punch
7/8" wrench (2)	Adjustable filter wrench	Hammer
15/16" wrench	Drain oil pan	Vice
5/16" Allen wrench		

B. Filter selection

Any one of 8 different size AMSOIL Full-Flow Oil Filters and 3 different AMSOIL By-Pass Filters may be used with this mount. Select a full-flow filter that is equivalent or larger than the one originally installed on your vehicle. The larger the filter used, the greater the filtration capacity and the longer the filter life. The By-Pass filter should be the largest for which space is available. Use the dimension information below as well as the data in diagram A to assist you in selecting your filters.

AMSOIL filters

Full-flow	DIA.	Height	By-Pass	DIA.	Height
EaO-26*	3.66"	6.85"	EaBP-110	4.29"	10.44"
EaO-15*	3.66"	5.35"	EaBP-100	4.29"	7.25"
EaO-96	3.66"	4.21"	EaBP-90*	4.29"	5.78"
EaO-42	3.66"	3.95"			
EaO-34	3.02"	4.72"	* Most commonly used filters		
EaO-57	2.92"	3.40"			
EaO-10	2.69"	3.40"			

1. Survey the engine compartment for possible mounting locations. The mount should be located as close to the existing full-flow filter as possible. Solid structures such as firewall, fender well, radiator support or frame are common locations. **(Do not mount on engine.)** Refer to diagram A for minimum area requirements and consider accessibility for servicing.
2. The filter mount can be rotated 180° in its mounting brackets. This allows the oil supply and return hoses to enter the mount on either the right or left hand side. Choose the side that will minimize the need for bends in the hoses or hose fittings. Also, refer to diagram B for preferred mounting angle positions.
3. When the locations has been determined, use the mounting template provided to locate and mark mounting holes. This can be easily done with a center punch and hammer.
4. With a 1/4" drill bit, drill out the previously marked mounting holes and attach the two piece mount bracket. Use the 4 - 1" long 1/4" bolts, nuts, small washer and fender washers provided. Note the assembly diagram D for details. Using two 7/16" wrenches or socket, tightened to 8 foot pounds.
5. Apply thread sealant onto the two "O" ring adapter fittings (BP-189) as noted in diagram E. Install fittings in mount end adjacent to the arrows. Using a 7/8" wrench tighten to 40-43 foot pounds. If desired, optional 90° angle fitting (BK-11) or 45° angle fittings (BK-12) may be installed at this time. Sold in packages of two, they are available from AMSOIL INC. **Do not** use thread sealant on either end of the angle fittings, tighten to 525-575 inch pounds or from finger tight rotate an additional 60° or 1/4 of a turn. Keep in mind the direction you wish to have the hoses intersect the mount.

6. Apply thread sealant as noted in diagram E to the Allen head "O" ring plug (BP-191). Using a 5/16" Allen head wrench, install plug in remaining mount port and tighten to 40-43 foot pounds. **Note:** If optional oil sampling valve is to be used, refer to diagram D and install in place of the Allen head "O" ring plug. Apply thread sealant to the external threads on all components in the BK-13 kit.

7. Attach the filter mount to the mounting brackets using 4-1 1/2" long 1/4" bolts, nuts and washers provided. **Warning:** The bolts **must** be installed so that the nuts are on the side opposite the filter nipples. Failure to do this will result in the bolts hitting the oil filters. Using two 7/16" wrenches or socket, tighten to 8 foot pounds.

C. Oil Supply

1. Using a 13/16" wrench, install two adapter fittings (BP-190) into the Spin-On filter adapter (BP-159) using thread sealant as noted in diagram E. Tighten to 28 foot pounds or 2-3 turns beyond finger tight.
2. Using an oil drain pan to control any loss of oil, remove the existing engine full-flow oil filter. Clean the gasket seating area on the engine with a clean lint free cloth.
3. With the engine filter nipple now exposed, match it with one of the four color-coded adapter bushings (BP-163 through 166). The correct bushing will thread on the nipple easily and with little free play. If you were previously using an AMSOIL Full-Flow Oil Filter or know the nipple thread size, use diagram F to determine the proper Adapter bushing color.
4. Apply thread sealant to the outside thread of the selected bushing as noted in diagram E.
5. With the knurled end of the bushing pointing out, thread into the spin-on filter adapter (BP-159).
6. Two "O" ring sizes and an adapter plate (BP-160) are provided to accommodate a variety of filter gasket seating areas. Compare the "O" rings with the gasket on the filter you just removed. Use the "O" ring that is the closest match. If the larger "O" ring is to be used, so must the adapter plate (BP-160) and small "O" ring. **Note:** The large "O" ring and adapter plate are normally only required in applications in which the engine calls for an AMSOIL EaO 24 or EaO 25 or equivalent full-flow oil filter.
7. To ensure proper sealing and aid in installation, place a small amount of grease on both sides of the "O" ring(s) used. Install the spin-on filter adapter and adapter plate, if required, in place of the old oil filter. Tighten the adapter one full turn after adapter first contacts sealing surface, back off slightly, about 1/8".

D. Oil feed and return lines

Note: The hose and hose fittings supplied with this kit have been matched to provide maximum performance and life expectancy. Interchanging with other types or brands is **not recommended** and **should be avoided.** Should additional hose be required, it may be obtained from AMSOIL INC. by ordering part number BP-250.

1. (Oil supply hose) Measure the amount of hose (BP-250) you will need to run from the **Red** colored port (labeled **Out**) on the spin-on adapter to the port with the arrow pointing **In**, on the filter mount. Additional length will be required to accommodate engine movement during operation. Also consider how the hose will be routed. Make sure the hose does not contact any hot or moving surfaces or sharp edges. Ensure a minimum bend radius of 1 1/2" is maintained at all corners. Bends in hose should not begin at hose fittings. See diagrams C and H for additional details.
2. Using a utility knife, squarely cut the hose to the proper length.
3. Install hose fittings (BP-260) on both ends of the hose. Follow the instructions noted in diagram G. Tools required are one 7/8" wrench and one 15/16" wrench or vise. **Note:** Do not use any form of thread sealant anywhere on the BP-260 hose fittings.
4. Route the hose assembly as noted in instruction D.1 and connect the hose fittings. **Note:** Optional 90° or 45° angle fittings may be installed at this time between the hose fittings and spin-on-adapter.
5. Using two 7/8" wrenches, tighten hose fitting swivel nuts and swivel nuts on angle fittings (if used) to 525-575 inch pounds or from finger tight, rotate an additional 60° or 1/4 of a turn. **Note:** Do not use any form of thread sealant anywhere on the hose or angle fittings.
6. (Oil return hose) Repeat steps D.1 through D.5. Connect hose at port labeled **In** (without red paint) on the spin-on adapter to the port with the arrow pointing **Out**, on the filter mount.
7. Use plastic ties (BP-46) to secure hose in position and away from damage. Trim ties using a side cutter. **Note:** Over tightening the plastic ties may cause the hose to collapse and restrict oil flow.

- Fill the selected Full-Flow and By-Pass Filters with the same motor oil being used in the vehicle. Lubricate the filter gaskets with oil and spin filters onto mount. Tighten per instructions on filter can.

E. Start up procedures

- Check that all fittings and hoses are securely attached, and that the hoses are routed properly.
- Check engine oil level. Fill to full mark if necessary.
- Set vehicle parking brake, With transmission in park/neutral start the engine and immediately check oil pressure. **Note:** Pressure may initially take a moment or two to rise.

Caution: Carefully check for leaks at fittings, hoses and mount. If leaks are observed, **STOP ENGINE IMMEDIATELY**, repair leaks and continue.

- After engine has warmed, shut off and re-check engine oil level. Fill as necessary.
- Record vehicle mileage/operating hours and date of installation.

F. Periodic maintenance

- Periodic visual inspection of the fittings and hoses is recommended. Check for leaks, hose deterioration and cuts. Repair and/or replace as necessary.
- Refer to Recommended Filter Change Interval chart for servicing intervals.
- To change the filter elements:
 - Ensure engine is off and use caution as the engine, oil and filter may be hot and could result in an injury.
 - Using a filter wrench, remove the filter elements. Dispose of properly.
 - Clean the filter gasket contact areas on the mount with a clean, lint-free rag.
 - Lubricate the new filter gaskets with clean oil or grease.
 - Fill filters as full as possible with engine oil.
 - Screw on new filters, tighten per instructions on filter can.
 - Start engine and check for leaks.
 - Check engine oil level, fill as needed.
- Record vehicle mileage/operating hours for future reference.

Parts and assembly list

Item	Description	Qty.	Part No.
1.	Filter Mount Assembly	1	BK-209
2.	Allen Head Plug	2	BP-191
3.	1/4" 20 x 1" Hex Head Bolt	4	BP-23
4.	1/4" I.D. Washer	6	BP-21
5.	1/4" 20 Self Locking Nuts	8	BP-22
6.	Adapter Fitting 3/8 NPT-1/2 JIC	2	BP-190
7.	"O" Ring Fitting Adapter 3/4"-16 x 1/2" JIC	2	BP-189
8.	Hose Fitting	4	BP-260
9.	1 3/32" I.D. Hose	8'	BP-250
10.	Spin-On Casting	1	BP-159
11.	"O" Ring Small 2 1/2" I.D.	1	BP-196
12.	"O" Ring Casting	1	BP-160
13.	"O" Ring Large 3 1/8" I.D.	1	BP-162
14A.	Thread Adapter 3/4"-16 (white)	1	BP-163
14B.	Thread Adapter		
	1 3/16"-16 and 20 mm-1.5 mm (blue)	1	BP-164
14C.	Thread Adapter 18mm-1.5 mm (red)	1	BP-165
14D.	Thread Adapter 22mm-1.5 mm (yellow)	1	BP-166
15.	Mounting Bracket (top)	1	BP-194
16.	Mounting Bracket (bottom)	1	BP-195
17.	1/4"-20 x 1 1/2" Hex Head Bolt	4	BP-185
18.	1/4" I.D. Fender Washer	4	BP-186
	Plastic Tie	2	BP-46
	Thread Sealant	1	BP-198
	Instruction Sheet	1	BP-152

Optional Parts Available From AMSOIL INC.

90° Fitting, Pack of 2	BK-11
45° Fitting, Pack of 2	BK-12
Oil Sampling Kit	BK-13

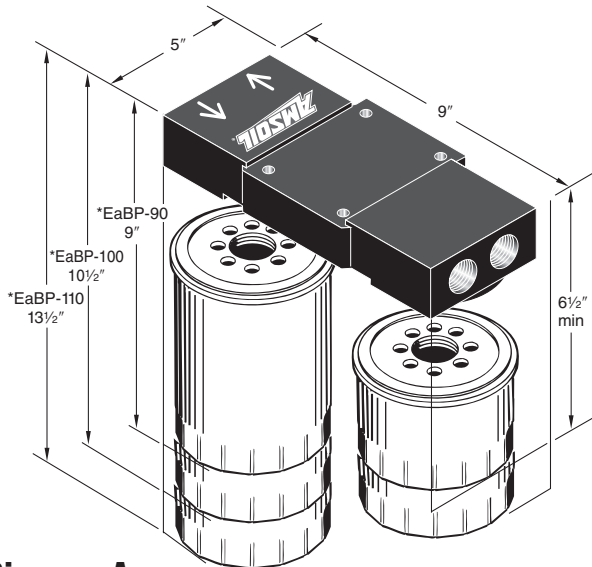

Diagram A

MINIMUM AREA NEEDED FOR
DUAL MOUNT AND SPIN-ON OIL FILTER ELEMENTS

* Mount and element heights plus 1-inch removal clearance

Mounting Angle Diagram B

(Recommendations are the same right to left and front to back)
Mounting angle above horizontal is not recommended

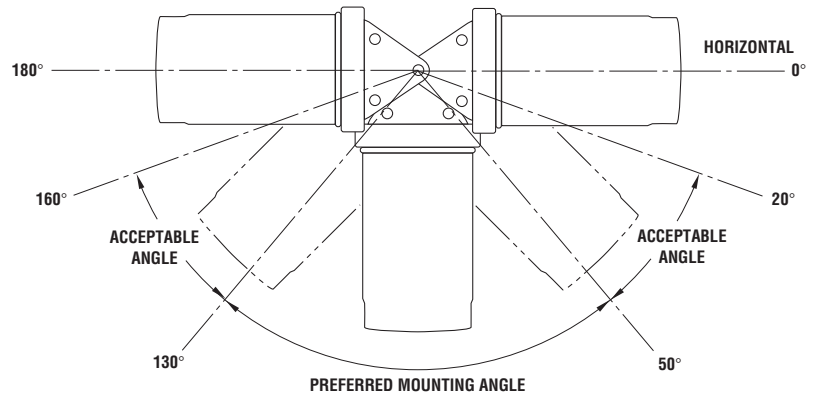

Diagram C

Minimum Bend Radius
(Actual size)

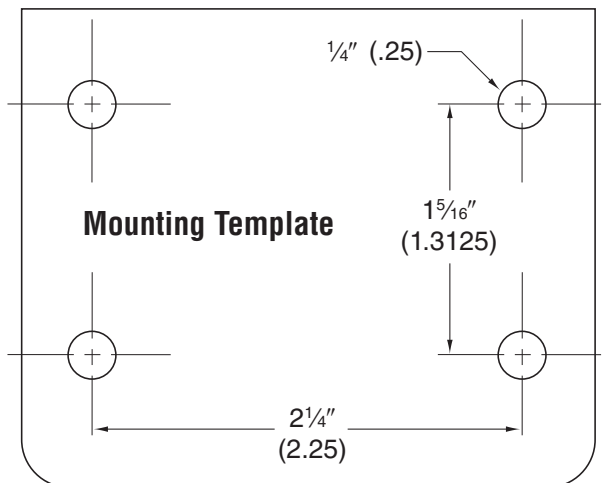
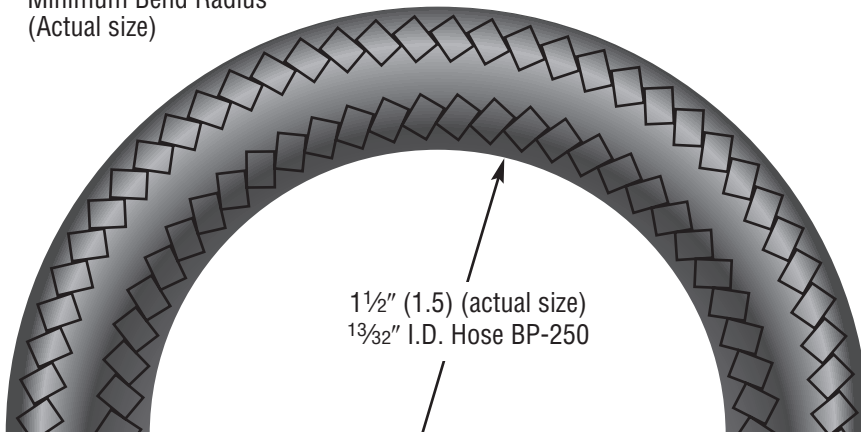
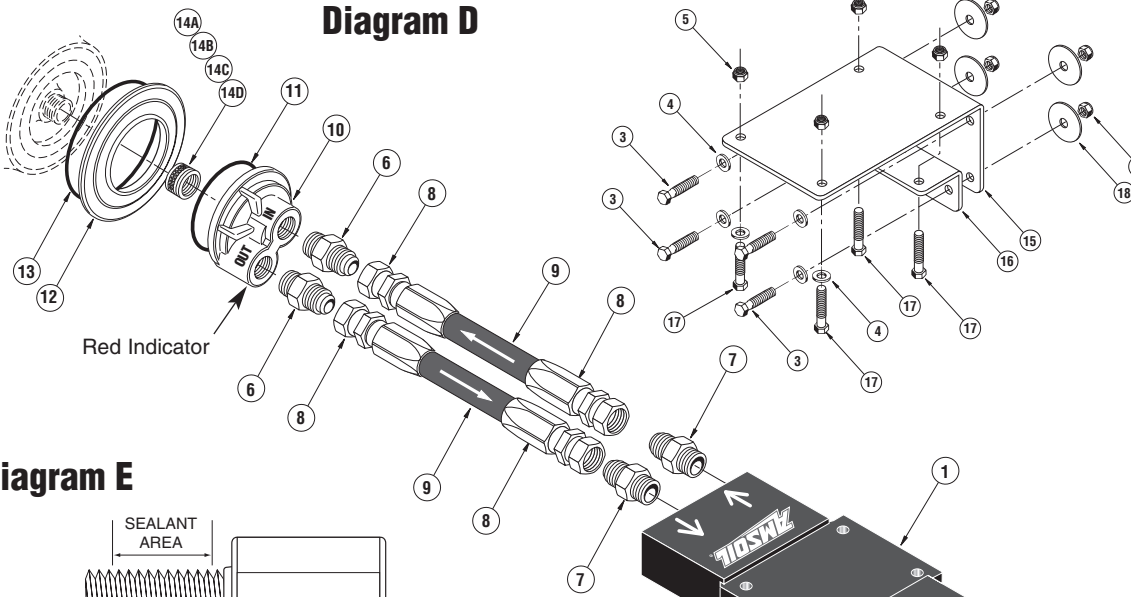

Diagram D



INSTALLING AN OIL SAMPLING PETCOCK ON THE SPIN-ON BY-PASS:

Getting a clean and uncontaminated oil sample is easy and simple when an oil sampling pet-cock is installed into the Spin-On By-Pass Oil Filter system. This can be easily done by ordering a BK-13 Kit.

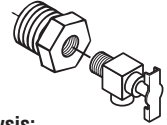
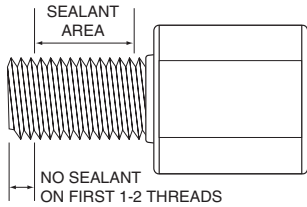
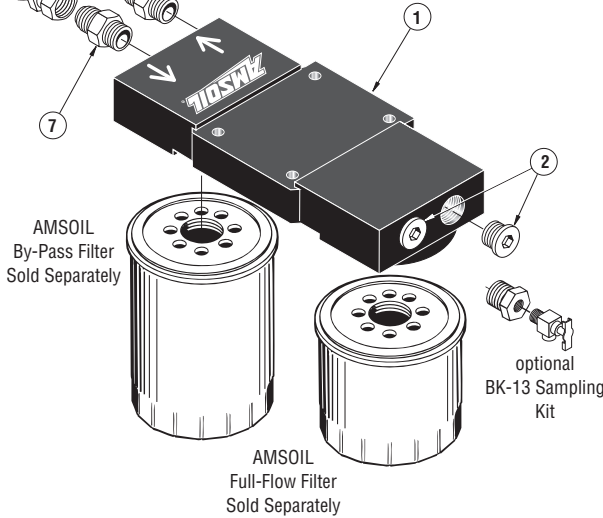

Diagram E



Note: If Teflon tape is used, it should be wrapped no more than 1½ to 2 turns in a clockwise direction when viewed from the thread end.

Caution: More than two turns of tape may cause distortion or cracking of the port. Never back off (loosen) pipe threaded connectors to achieve alignment.



Oil Analysis:

- If installing By-Pass Oil Filter with AMSOIL Air Filter and 100% Synthetic Engine Oil in a pleasure vehicle, we recommend the TRIGARD Oil Analysis Program:
 - TRIGARD 1 (Stock No. ATG-01) is the starter program. It contains registration material and 2 **prepaid** analysis to check oil's condition.
 - TRIGARD 2 (ATG-02) is for all subsequent oil samples. Each ATG-02 also contains materials for 2 prepaid oil analysis.
- For other oil analysis or commercial vehicles, order G-1318 Oil Analysis Sampling Kits (in U.S., Canada), or send samples to the lab of your choice. Consult AMSOIL Technical Service for details.

Diagram F Thread adapters

If your vehicle uses this AMSOIL Filter This is the thread used on that vehicle This is the bushing color you should use

EaO-09	¾" - 16	White
EaO-10	¾" - 16	White
EaO-11	22mm x 1.5mm	Yellow
EaO-12	20mm x 1.5mm	Blue
EaO-13	20mm x 1.5mm	Blue
EaO-14	20mm x 1.5mm	Blue
EaO-15	¾" - 16	White
EaO-20	20mm x 1.5mm	Blue
EaO-21	20mm x 1.5mm	Blue
EaO-22	1¾" - 16	Blue
EaO-23	18mm x 1.5mm	Red
EaO-24	1¾" - 16	Blue
EaO-25	1¾" - 16	Blue
EaO-26	¾" - 16	White
EaO-27	1¾" - 16	Blue
EaO-29	18mm x 1.5mm	Red
EaO-30	1¾" - 16	Blue
EaO-31	1¾" - 16	Blue
EaO-32	1¾" - 16	Blue
EaO-34	¾" - 16	White
EaO-36	20mm x 1.5mm	Blue
EaO-40	¾" - 16	White
EaO-41	¾" - 16	White
EaO-42	¾" - 16	White
EaO-44	20mm x 1.5mm	Blue
EaO-52	1¾" - 16	Blue
EaO-57	¾" - 16	White
EaO-58	¾" - 16	White
EaO-59	1¾" - 16	Blue
EaO-64	1¾" - 16	Blue
EaO-76	1¾" - 16	Blue
EaO-88	Cartridge	N/A
EaO-96	¾" - 16	White
EaO-99	1½" - 16	Use BMK-16
EaO-80	1 - 16	Use BMK-15

Adapters

White	¾" - 16
Red	18mm x 1.5mm
Yellow	22mm x 1.5mm
Blue	20mm x 1.5mm and 1¾" - 16

Diagram G



- Place socket in vice and screw in hose counter-clockwise until hose bottoms. Back hose out ½ turn.



- Oil inside of hose and nipple threads liberally with oil. Do not oil hose cover.

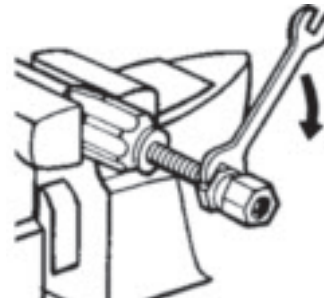

- Screw nipple assembly into socket using wrench on nipple hex until nipple hex shoulders against socket.

BMK-13 PARTS IDENTIFICATION SHEET

(2) BP-46
PLASTIC TIE



(1) BP-165
ADAPTER RED
18 mm - 1.5 mm



(6) BP-21
1/4" I.D. WASHER



(1) BP-166
ADAPTER YELLOW
22 mm - 1.5 mm



(8) BP-22
1/4" NUT



(4) BP-185
1/4" X 1 1/2"
BOLT

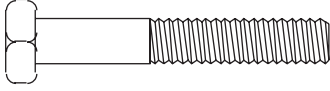

(4) BP-23
1/4" X 1" BOLT



(4) BP-186
1/4" FENDER
WASHER



(1) BP-159
FILTER ADAPTER
NOT TO SCALE

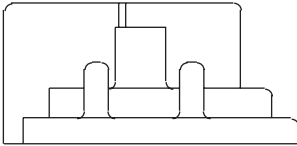

(1) BP-160
"O" RING CASTING
NOT TO SCALE



(4) BP-260
HOSE FITTING

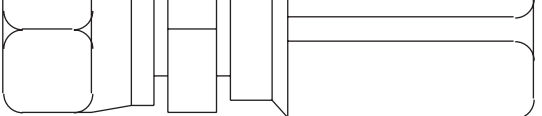

(1) BP-162
LARGE "O" RING
3 1/8" I.D.
NOT TO SCALE



(1) BP-163
ADAPTER WHITE
3/4" - 16



(8) BP-250
1 3/32" HOSE
AMSOIL BP - 250



(1) BP-164
ADAPTER BLUE
1 3/16" - 16
20 mm - 1.5 mm



(2) BP-189
"O" RING
FITTING
ADAPTER

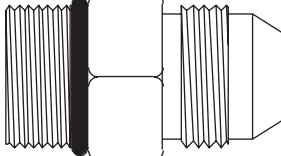

BMK-13: PAGE TWO

(2) **BP-190**
ADAPTER
FITTING

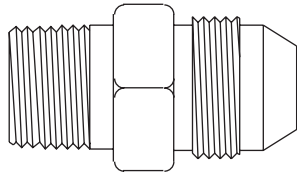

(1) **BP-191**
ALLEN HEAD
PLUG

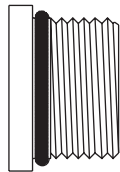

(1) **BP-196**
SMALL "O" RING
2 1/2" I.D.



(1) **BP-194**
MOUNTING
BRACKET
TOP

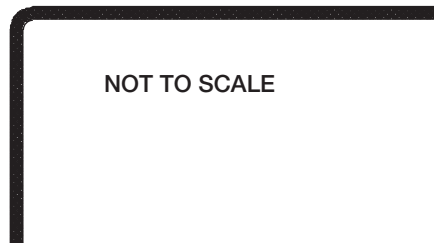

(1) **BP-195**
MOUNTING
BRACKET
BOTTOM

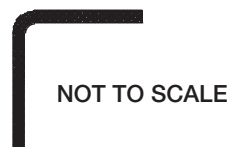

(1) **BK-209**
FILTER MOUNT
ASSEMBLY

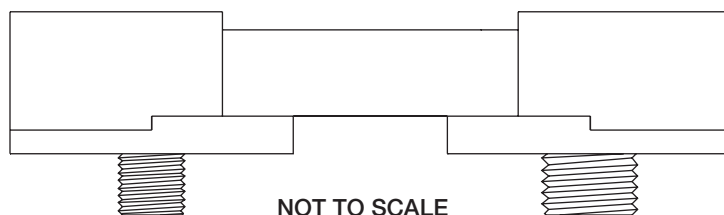
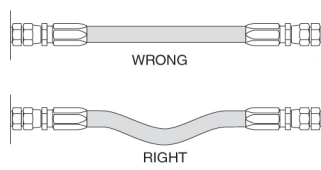
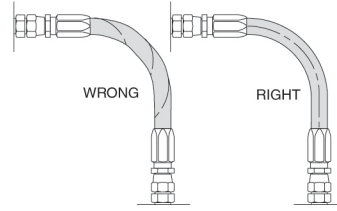

Diagram H Hose routing examples



1. Provide for length change

In straight hose installations allow enough slack in the hose line to provide for changes in length that will occur when pressure is applied. This change in length can be from +2% to -4%.



2. Avoid twisting and orient properly

Do not twist hose during installation. This can be determined by the printed layline on the hose. Pressure applied to a twisted hose can cause hose failure or loosening of connections.

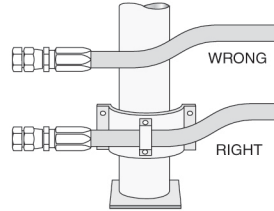

3. Protect from hazardous environment

Keep hose away from hot parts. High ambient temperature will shorten hose life. If you can not route it away from the heat source, insulate it.

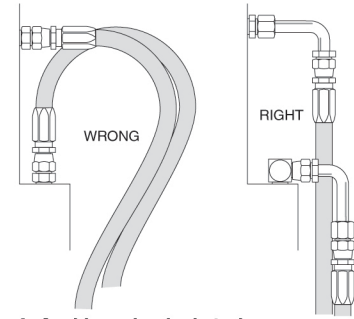

4. Avoid mechanical strain

Use elbows and adapters in the installation to relieve strain on the assembly, and to provide easier and neater installations that are accessible for inspection and maintenance.

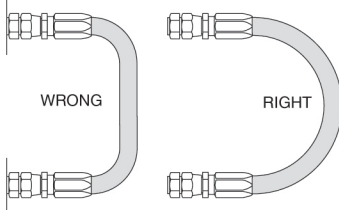

5. Use proper bend radius

Keep the bend radius of the hose as large as possible to avoid collapsing of the hose and restriction of flow. Follow catalog specs on minimum bend radii.

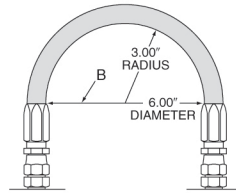

6. Use proper bend radius (cont.)

Maximum bend radius is measured on the inside bend of the hose. To determine minimum bend, divide the total distance between ends (B length) by 2. For example 8 = 6, minimum bend radius = 3.

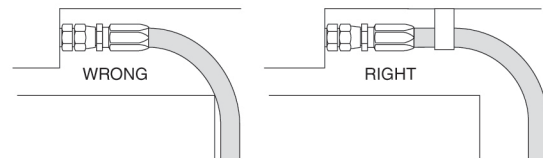

7. Secure for protection

Install hose runs to avoid rubbing or abrasion. Use clamps to support long runs of hose or to keep hose away from moving parts. It is important that the clamps do not allow the hose to move. This movement will cause abrasion and premature hose failure.

8. Avoid Improper Hose Movement

Make sure relative motion of the machine components produces bending rather than twisting of the hose. Hose should be routed so that the flex is in the same plane as the equipment movement.

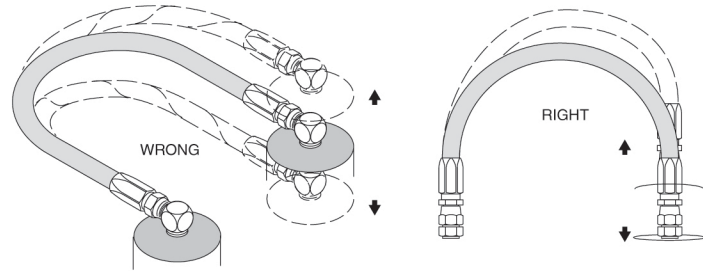

Recommended Filter Change Intervals

Follow these change intervals when using the By-Pass Oil Filter recommended for your size engine (i.e. EaBP-90 up to 9 qts.; EaBP-100 up to 15 qts.; EaBP-110 up to 21 qts.). Contact the AMSOIL Technical Service Department for change intervals when using other than the recommended size filter element.

AMSOIL Oil Filter Change Recommendations

Vehicles with Gasoline or Diesel Fueled Engines

- **EaO and Donaldson Endurance ELF 7349** (Dodge Cummins 5.9L): Up to 25,000 miles (15,000 miles for severe service) or one-year service life, whichever comes first, when used in conjunction with AMSOIL Synthetic oil. Always change oil filter at time of oil change.
- **EaBP By-pass Filters:** Should be changed every other full flow filter change or up to 60,000 miles, whichever comes first. When used with other brands of motor oil or full flow filters, the EaBP should be changed every other full flow filter change. AMSOIL recommends using oil analysis when extending oil drain intervals.
- **Donaldson Endurance:** Heavy-duty commercial vehicles and off road equipment, when used in conjunction with AMSOIL Synthetic oil, up to two times longer than OEM* recommendations, not to exceed 60,000 miles for on-highway diesel applications. Always change oil filter at the time of oil change.
- **WIX and Donaldson "P" Series:** OEM* Recommendations.

Stationary Engines

- **EaO and Donaldson Endurance:** Up to two times longer than OEM* recommendations. Always change oil filter at time of oil change.
- **WIX and Donaldson "P" Series:** OEM* Recommendations.

To order By-Pass Oil Filter Parts or oil sample kits, consult your AMSOIL Dealer or the AMSOIL Product Price List for your country. Most of these items are available from your AMSOIL Product Center.