

Engine Liquid Filtration

Lube/Oil, Fuel, Coolant, Hydraulic and Transmission



Since 1915, we have delivered innovative filtration solutions that protect engine components to extend the life of your equipment.

If you are looking for quality filtration replacement products with local availability – Demand Donaldson.

Donaldson®



Liquid Filtration Solutions

...engineered by Donaldson



Coolant

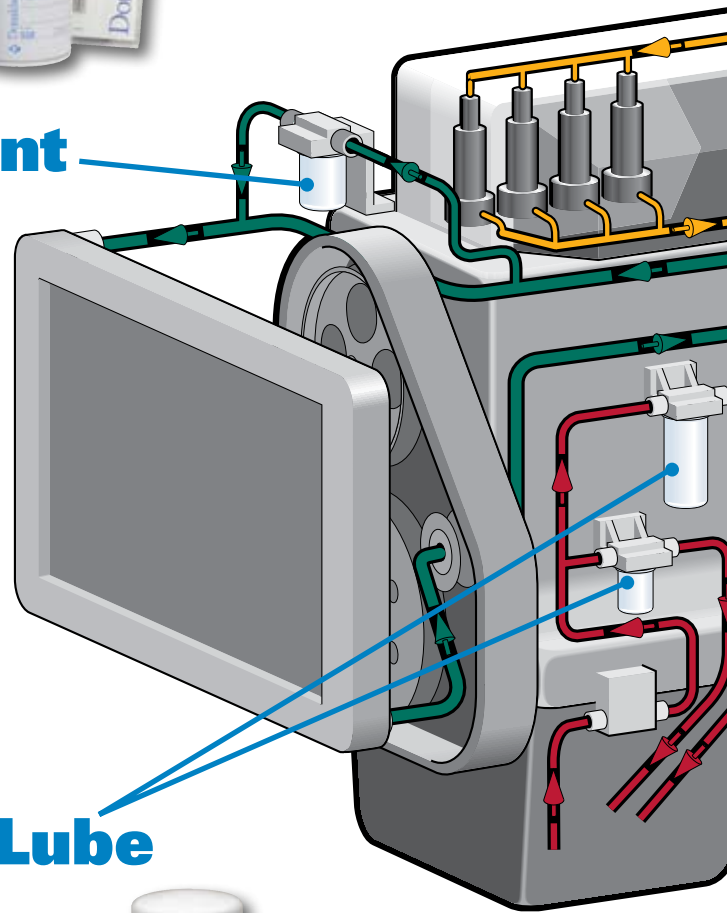

Lube



Changes in emission laws and new technologies are placing ever increasing demands on filtration systems. Today's diesel engines run at higher temperatures and require optimum filtration performance. Donaldson's complete line of liquid filters are designed to meet the needs of the engine application. With greater efficiency, more capacity and long service life you get maximum engine protection.

You can be certain that Donaldson filters will perform in the most demanding environments.

Key Filter Design Criteria

- The right media choice
- The right combination of efficiency, pressure drop, and loading
- The right balance of efficiency, durability and capacity
- The optimum performance and service life
- The right configuration

Donaldson Filters Deliver

- Increased engine protection
- Extended service intervals
- Reduced operating costs
- Optimum fuel efficiency
- Reduced maintenance

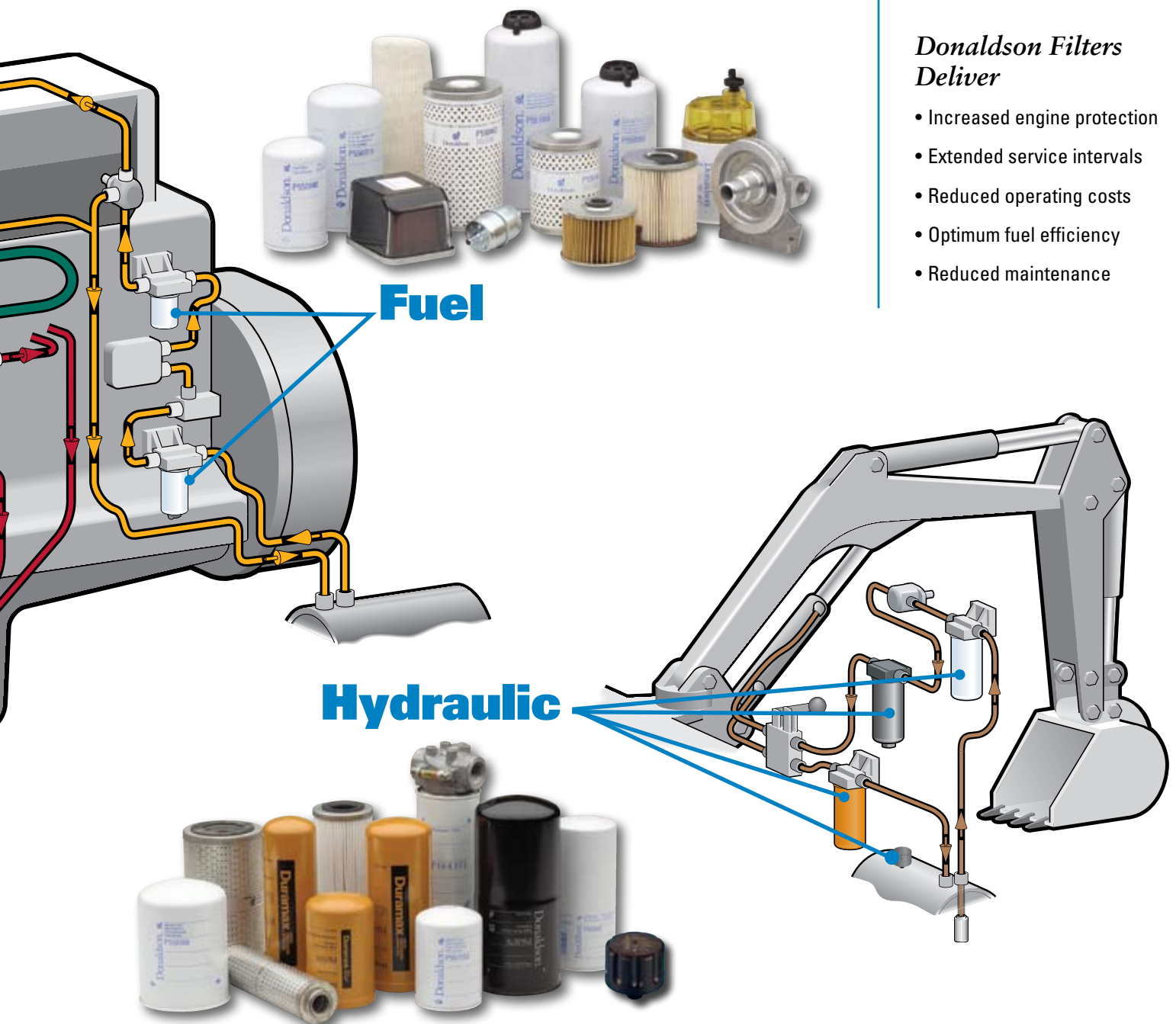

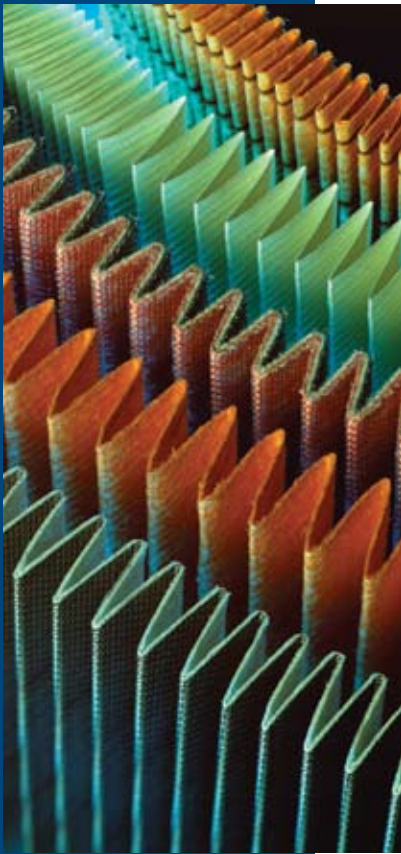

Powerful performance

...Donaldson media formulations set the standard for filtration performance!

Donaldson filter media technology choices for liquid filters are extensive – we have over 35 different formulations. The various formulations enable our engineers to develop filtration systems that exceed or match our customers' specifications.

When an application requires higher efficiency filtration than cellulose filter media can deliver, Donaldson uses synthetic media technology. Synthetic media captures more and smaller contaminant than cellulose media.

Synteq for Lube and Hydraulic Filtration

Synteq filter media technology in Donaldson Endurance lube filters is ideal for equipment owners that want to extend their oil drain intervals. In hydraulic filters, Synteq filter media technology delivers improved filtration performance.

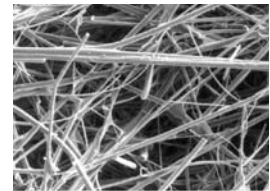

Synteq for Fuel Filtration

This multiple-layered media technology is designed specifically to remove water AND contaminant from the fuel stream.



Synteq for Coolant Filtration

Synteq filter technology in our Donaldson Endurance Plus coolant filters are designed with the efficiency and capacity to allow for extended drain intervals.

Media Durability

Donaldson uses a variety of techniques to enhance the filter media so it can withstand the working pressures that range up to 1000 psi (6895 kPa). Oven-curing, wire backing and multiple layers all contribute to our media integrity.



Look for the Synteq brand mark or name on Donaldson lube, fuel, coolant and hydraulic filters with synthetic media.

Designed for Durability

With quality systems and processes in place throughout our entire company, Donaldson customers have come to expect reliable and consistent quality.

Thread Plate

The tapered thread profile makes our filters easy to install with almost no chance of cross threading. Fully tucked seams attach the thread plate to the housing can for strength and durability.

Housing Can

Heavy-duty, coated shell, rounded dome and corner radius give Donaldson filters superior pressure fatigue performance.

Filter Cartridge

Donaldson has design and manufacturing experience with both metal (traditional) and metal-free cartridge filters.

Center Tube

The Donaldson louvered center tube and spiral lock seam design allows more flow area with greater collapse strength. The louvers all face the center of the filter, keeping the media side surface smooth, which eliminates pleat tip wear.

Gaskets

Oil, fuel and hydraulic fluids have their own unique chemical properties. Donaldson makes sure the right materials are used and the right shape to fit the mounting head or housing. In spin-on filters, the inner seal between the thread plate and filter cartridge is critical.

Inner Seals

In spin-on filters, the inner seal between the thread plate and filter cartridge is another critical seal. Donaldson filters use a molded elastomer seal. Competitive designs use non-heavy-duty materials, like paper, cork, and spacers.

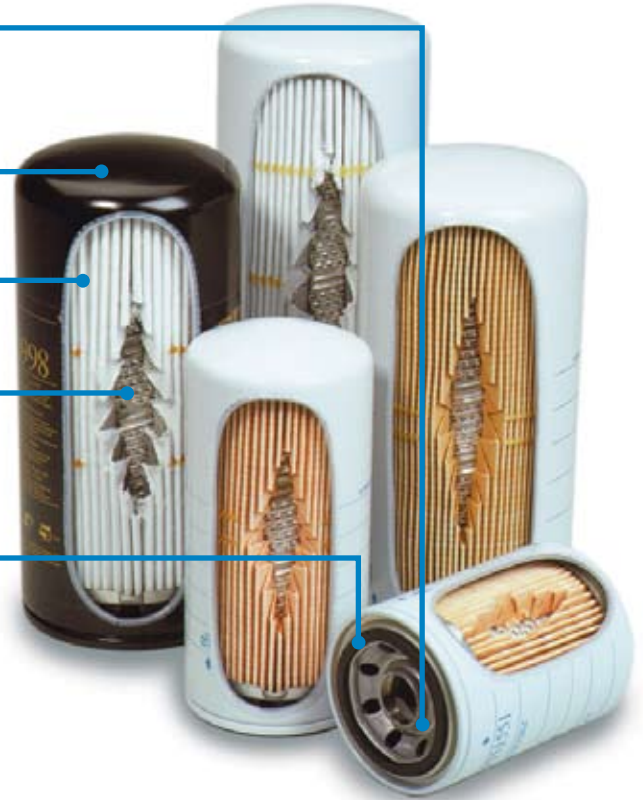

Liquid System Design Features

Electronic sensors, indicators, mounting heads, and unique drain valves are all features that Donaldson engineers continue to develop for our customers.



Our programmable differential pressure sensor uses advanced electronics to deliver cost-effective, customized output on pressure sensitive systems.

Extensive Research and Product Development

Donaldson design and quality standards ensure that our liquid filtration solutions are right on target. From vibration and compression testing to fluid analysis and laser particle counting, our testing labs fully support the broad range of testing requirements to analyze filtration needs and verify product performance.



Donaldson facilities are QS and TS certified. Visit our web site for details.



Lube Filtration

meeting the most
demanding

Oil is vital to your engine's moving parts. It lubricates, removes heat as it circulates and flushes contaminants out of the engine.

Donaldson lube filters keep engine oil clean by capturing contaminants that can cause engine damage. New engine designs require finer filtration than older engines. Increased engine emissions control and tighter tolerances within the engine require high efficiency filters.

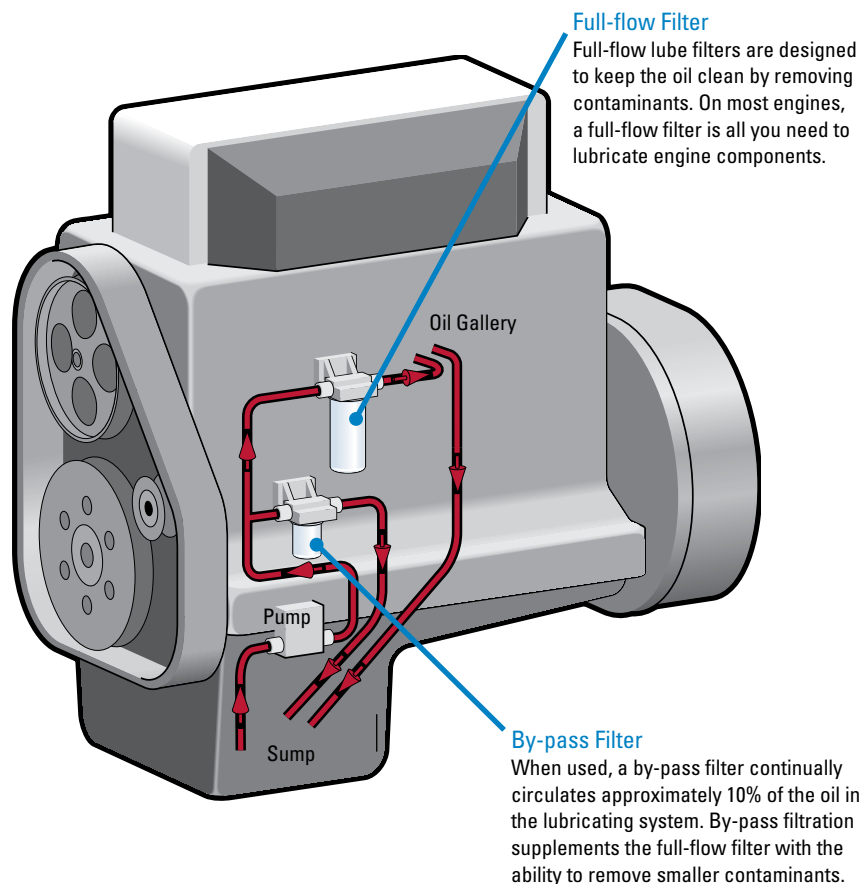

specs

Spin-on Filters

Donaldson durable lube filters keep your equipment running at its best to let you focus on what's most important, getting your job done.



Donaldson Endurance™ Plus Additive Replenishment Technology Filters

These filters are designed for today's emissions compliant EGR engines, use a controlled chemical release process to replenish the additives in the engine oil and deliver extended drain intervals, often double that of standard filters. These filters – for use with Pre-EPA 2007 compliant engines only – are a direct replacement and require no system modifications or special maintenance.



Cartridge-style Filters

Donaldson offers a complete line of cartridge-style lube filters for all makes of equipment.



Applied Technology

Donaldson has applied its Radial Seal Technology to spin-on style lube filters. The radial seal design provides a consistent, reliable seal, enhanced structural performance and optimum protection.



Donaldson filters are protected internationally by patents and trademarks; both issued and pending.

Cleaner fuel

means

longer injector and pump life

Today's engines are built to more stringent specifications and finer tolerances. Fuel systems, pumps and injectors require cleaner fuel to achieve better combustion and lower emissions. That's why the latest advances in filter media can make the difference between engine power and engine problems.

The engine configuration below depicts a system with a fuel filter water separator and a spin-on fuel filter.

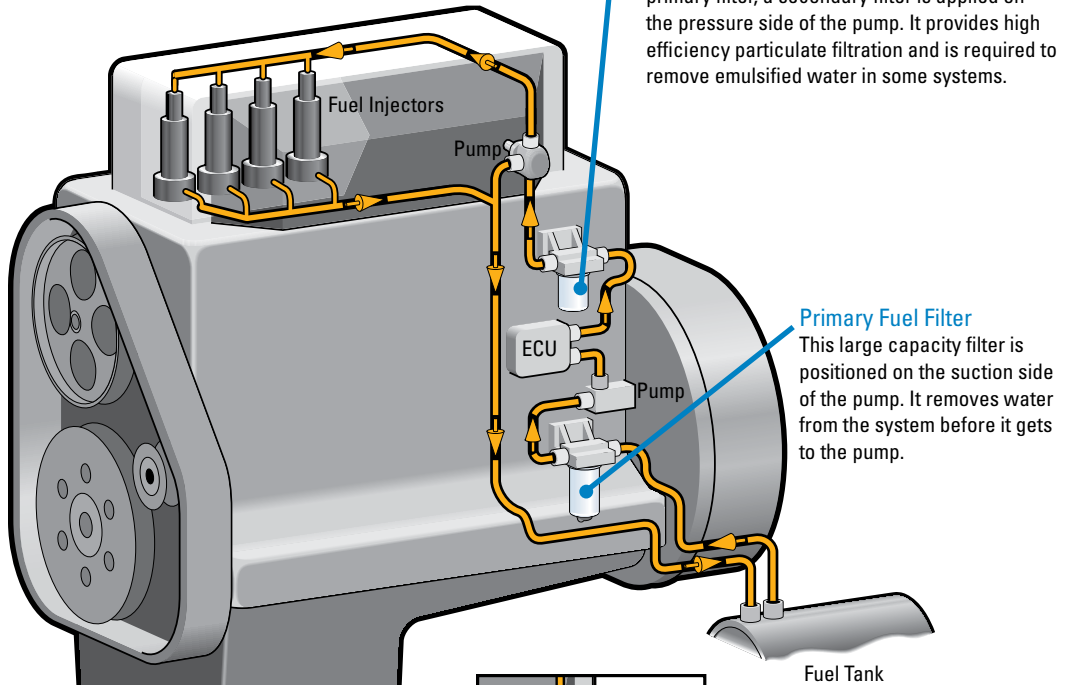

This configuration depicts a system with a fuel processor and a bowl cartridge, each containing a cartridge-style fuel filter.

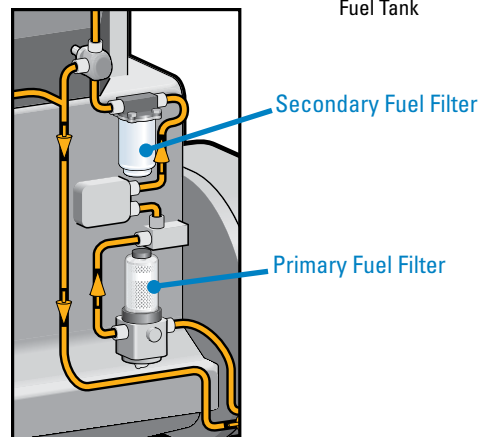

Primary & Secondary Fuel Filters

Our fuel filters provide clean, filtered fuel that prevents pump wear, injector clogging, premature engine wear and can boost fuel efficiency. Donaldson has a complete line of spin-on, and cartridge-style filters.



Fuel Filter/Water Separators

Our durable fuel filter/water separators and companion head assemblies fit a wide variety of applications that have flow ranges.

The filters trap contaminants carried in the fuel and strip away water that can damage your engine. They are compatible with petroleum-based, ULSD and OEM approved Biodiesel fuels. Most spin-on filters feature our Donaldson Twist&Drain™ valve that turns the messy and complicated task of draining water from the fuel filter into the easy process it should be.



Synteq™ Fuel Media Technology

Give your engine a higher level of protection and prolong its service life with Donaldson fuel filters made with Synteq media technology.



High Efficiency Fuel Filters

The fuel system designs on newer engines are being modified to comply with tough emissions regulations and to improve fuel economy. These new systems utilize "common rail" design.

Engine engineers are faced with fuel systems that are less tolerant of contaminant and water in the system. Donaldson has filter technology solutions that can meet the filtration performance of the engine manufacturers.

You can depend on Donaldson filters to keep your engine running like new.

How Common Rail Fuel Systems Work

High-pressure fuel is distributed directly to the fuel injectors from an accumulator channel called the "rail." Your engine's Electronic Control Unit (ECU) precisely controls pressure in the rail and the operation of the injectors.

Balance

is the key in
Coolant Filtration

Rust. Scale. Debris. Your engine battles them. And when it loses, you pay.

Your cooling system keeps engine temperatures at the right level to dissipate heat and maintain the right operating conditions for optimal fuel economy. Donaldson coolant filters remove contaminants, minimize the risk of filter plugging and keep your engine running efficiently.

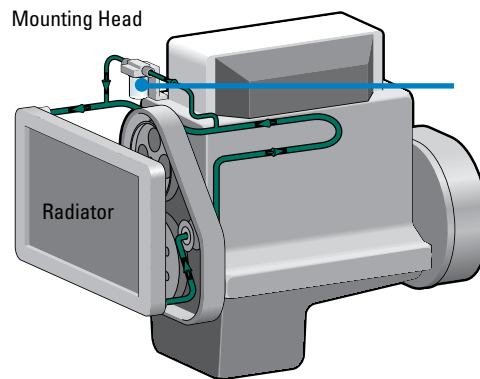

Coolant Filters

Coolant filters are designed to maintain the proper chemical balance and reduce contaminants in the engine cooling system.



SCA and SCA+ Filters

A complete line of replacement filters for diesel engines with various amounts of chemical treatment are available.



Coolant Treatment Maintenance

Our 3-way, coolant test strip is an fast and easy method to use during routine maintenance to adequately diagnose and supplement your coolant chemicals.



If you need to supplement your coolant additive package, use SCA and SCA+ chemical treatment available in many sizes from a pint to 55 gallon drum.

Extended Service Filters

Consider Donaldson Endurance coolant filters if you're interested in extending the life of your filter or Donaldson Endurance PLUS if you're looking to extended the life of your standard coolant.



Filtration

for hydraulic-powered

Equipment

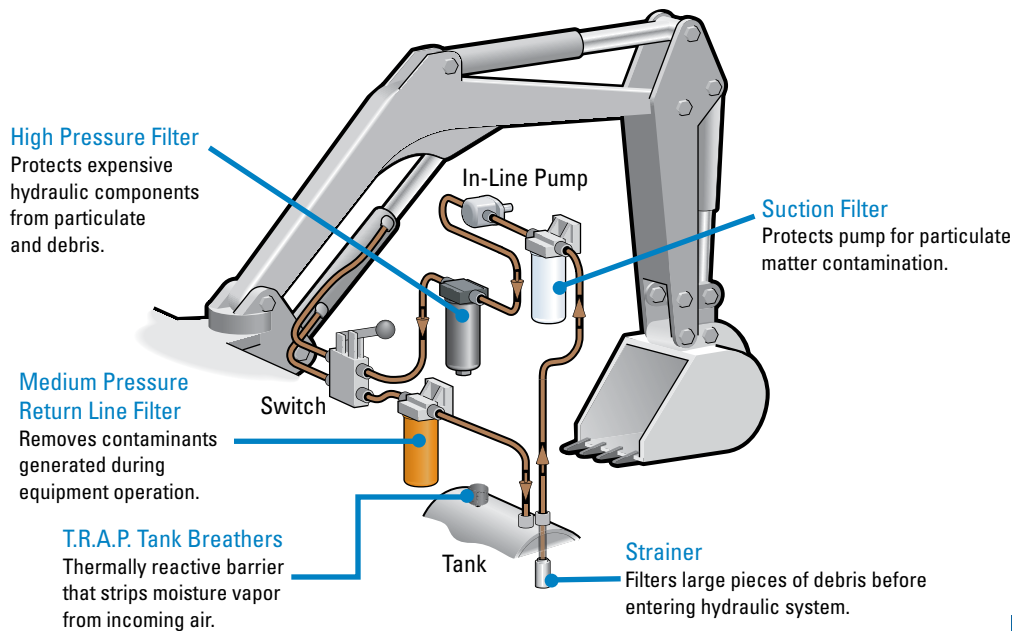

A Full Line of Hydraulic/Transmission Filters

Donaldson filters for mobile hydraulic systems are designed to keep the fluid and system as clean as necessary by removing particulate matter and debris which could ultimately cause component wear or failure.

Duramax HIGH PRESSURE SPIN-ON

Commonly recognized by our orange can, the Duramax® revolutionized the hydraulic industry when introduced in the 1970s.

Donaldson has an extensive line of hydraulic and transmission filters and system accessories. With our extensive stock program, you can mix and match filters with head assemblies to design a custom filtration system.

Donaldson offers a full line of hydraulic and transmission filters.



Demand Donaldson

Donaldson filtration solutions offer customers the information and products to turn engine durability and performance goals into the right filter choices.



Make Donaldson your single source for air, exhaust/ emissions, and liquid filtration solutions to increase engine protection, extend service intervals and reduce operating costs.

For information about these products, talk with your Donaldson representative. Call us or visit our web site at www.donaldson-filters.com.



Donaldson

Donaldson Company, Inc.
Minneapolis, MN
55440-1299

www.donaldson.com

Brochure No. F111021 (3/09)

© 2009 Donaldson Company, Inc.

Printed in the U.S.A.

Donaldson Company, Inc. reserves the right to change or discontinue any model or specification at any time and without notice.

North & South America
800-374-1374

Europe & Middle East
32-16-38-3811

Asia Pacific
65-6311-7373

South Africa
27-11-997-6000

Australia
61-24-350-2033